



User Guide

Catia V5 > Creo View

Product Category	CADTranslate
Product Group	CATIA V5 > Creo View
Product Release Version	27.1

Document Type	User Guide
Document Status	Released
Document Revision	1.0
Document Author	Product Manager
Document Issued	09/08/2024

📍 THEOREM HOUSE
MARSTON PARK
BONEHILL RD
TAMWORTH
B78 3HU
UNITED KINGDOM

☎ +44(0)1827 305 350

📍 THEOREM SOLUTIONS INC.
100 WEST BIG BEAVER
TROY
MICHIGAN
48084
USA

☎ +(513) 576 1100

Contents

Overview of TRANSLATE.....	4
<i>About Theorem.....</i>	<i>4</i>
<i>Theorem's Product Suite.....</i>	<i>5</i>
CADTranslate.....	5
CADPublish.....	5
TheoremXR.....	5
The CATIA V5 Bi-directional JT Translator.....	Error! Bookmark not defined.
<i>Primary Product Features.....</i>	<i>Error! Bookmark not defined.</i>
<i>Primary Product benefits?.....</i>	<i>Error! Bookmark not defined.</i>
Getting Started.....	6
<i>Documentation & Installation Media.....</i>	<i>6</i>
<i>Installation.....</i>	<i>6</i>
<i>License Configuration.....</i>	<i>6</i>
<i>Using the Product.....</i>	<i>6</i>
Using the Product.....	9
<i>Default Translations.....</i>	<i>Error! Bookmark not defined.</i>
Default Translation – via the Unified Interface.....	Error! Bookmark not defined.
Default Translation – via the Command Line.....	Error! Bookmark not defined.
Translator Customization.....	Error! Bookmark not defined.
<i>Common Options for CATIA V5 to JT.....</i>	<i>Error! Bookmark not defined.</i>
CATIA V5 Read Arguments.....	Error! Bookmark not defined.
JT Write Arguments.....	Error! Bookmark not defined.
CATIA V5 to JT Entity Masking Arguments.....	Error! Bookmark not defined.
CATIA V5 to JT General Arguments.....	Error! Bookmark not defined.
Processing CATIA V5 FTA data to JT PMI.....	Error! Bookmark not defined.
Options for Processing FTA Data with Filled Text.....	Error! Bookmark not defined.
Options for Processing FTA Data using Outline Text.....	Error! Bookmark not defined.
<i>Common Options for JT to CATIA V5.....</i>	<i>Error! Bookmark not defined.</i>
JT Read Arguments.....	Error! Bookmark not defined.
CATIA V5 Write Arguments.....	Error! Bookmark not defined.
JT to CATIA V5 General Arguments.....	Error! Bookmark not defined.
Command Line Advanced Arguments.....	Error! Bookmark not defined.
<i>CATIA V5 Advanced Arguments.....</i>	<i>Error! Bookmark not defined.</i>
<i>JT Advanced Arguments.....</i>	<i>Error! Bookmark not defined.</i>
CATIA V5 – JT PDF Add On Products.....	Error! Bookmark not defined.
Translating Interactively from within CATIA V5.....	Error! Bookmark not defined.
<i>Save As JT.....</i>	<i>Error! Bookmark not defined.</i>
<i>Open JT Data.....</i>	<i>Error! Bookmark not defined.</i>
Appendix A – CATIA V5 Configuration.....	Error! Bookmark not defined.

<i>Introduction.....</i>	<i>Error! Bookmark not defined.</i>
<i>Conventions.....</i>	<i>Error! Bookmark not defined.</i>
<i>CATIA V5 Installation Directory.....</i>	<i>Error! Bookmark not defined.</i>
<i>Running CATIA V5 Translators</i>	<i>Error! Bookmark not defined.</i>
<i>CATIA V5 Environment DIRENV & ENV.....</i>	<i>Error! Bookmark not defined.</i>
<i>Checking the CATIA V5 Environment.....</i>	<i>Error! Bookmark not defined.</i>
<i>Checking the Theorem Shared Library.....</i>	<i>Error! Bookmark not defined.</i>
Appendix B – JT Configuration File.....	Error! Bookmark not defined.
<i>Introduction.....</i>	<i>Error! Bookmark not defined.</i>
<i>The Setup Section.....</i>	<i>Error! Bookmark not defined.</i>
To edit setup options.....	Error! Bookmark not defined.
<i>The Filter Section.....</i>	<i>Error! Bookmark not defined.</i>
To edit filter options.....	Error! Bookmark not defined.
<i>The Metadata Section</i>	<i>Error! Bookmark not defined.</i>
To edit metadata options.....	Error! Bookmark not defined.
<i>The Level of Detail Section.....</i>	<i>Error! Bookmark not defined.</i>
<i>The JT Options Section.....</i>	<i>Error! Bookmark not defined.</i>
<i>The Catia5 Options Section</i>	<i>Error! Bookmark not defined.</i>
<i>The Catia4 Options Section</i>	<i>Error! Bookmark not defined.</i>
<i>The General Options Section</i>	<i>Error! Bookmark not defined.</i>
Appendix C – Error Codes.....	Error! Bookmark not defined.
<i>Common Error Codes.....</i>	<i>Error! Bookmark not defined.</i>

Overview of TRANSLATE

About Theorem



Theorem Solutions is a world leader in the field of Engineering Data Services and Solutions. This leadership position stems from the quality of our technology and the people in the company. Quality comes not only from the skills and commitment of our staff, but also from the vigorous industrial use of our technology & services by world leading customers.

We are proud that the vast majority of the world's leading Automotive, Aerospace, Defense, Power Generation and Transportation companies and their Supply chains use our products and services daily. Working closely with our customers, to both fully understand their requirements and feed their input into our development processes has significantly contributed to our technology and industry knowledge.

Theorem Solutions is an independent UK headquartered company incorporated in 1990, with sales and support offices in the UK and USA. Theorem has strong relationships with the major CAD and PLM vendors, including; Autodesk, Dassault Systemes, ICEM Technologies (a Dassault company), PTC, SolidWorks, Spatial Technology and Siemens PLM Software. These relationships enable us to deliver best in class services and solutions to engineering companies worldwide.

Theorem's Product Suite

Theorem have 3 main Product brands. These are:

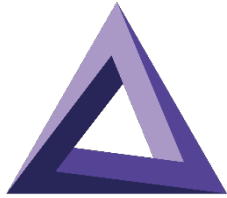

CADTranslate

CADTranslate

Direct translation of 3D data to or from an alternate CAD, Visualization or Standards Based format.

See our [website](#) for more detail.

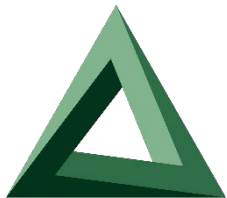

CADPublish

CADPublish

The creation of documents enriched with 3D content

See our [website](#) for more detail.



TheoremXR

TheoremXR

Visualization for [Augmented \(AR\)](#), [Mixed \(MR\)](#) and [Virtual \(VR\)](#) Reality applications

See our [website](#) for more detail.

Getting Started

Documentation & Installation Media

The latest copy of the User Guide documentation can be found on our web site at:

<http://www.theorem.com/Documentation>

Each product has a specific link that provides user documentation in the form of PDF and Tutorials.

The latest copy of Theorem software can be found via the link above and by searching for the specific product. Each product has a specific link to the Product Release Document, which contains a link to the download location of the installation CD.

Alternatively, you can request a copy of the software to be shipped on a physical CD.

Installation

The installation is run from the .msi file download provided. For full details of the installation process, visit www.theorem.com/documentation and select UI from the product selection list.

License Configuration

To run any product a valid license file is required. The Flex License Manager is run from the .msi file download provided. For full details of the installation process, visit www.theorem.com/documentation

Using the Product

To use the product, follow the documented steps found in this document or follow the online video tutorials which can be found from www.theorem.com/documentation

The CATIA V5 Creo View Adapter

Theorem's Visualize 3D product for CATIA V5 to Creo View is also known as The CATIA V5 Adapter for Creo View.

It is a direct data converter from CATIA V5 to Creo View, PTC's visual collaboration product. The Adapter rapidly and accurately publishes 3D mechanical design geometry parts, assemblies and 2D drawings, together with attribute information to the compact formats used by the Creo View application.

Designed to be compatible with other PTC Creo View Adapters, the Adapter can be integrated into Windchill, DIVISION Graphics Server or other PDM environments.

The Adapter directly accesses native CATIA V5 parts, assemblies and drawing files using the Dassault Systemes supported programming interface. Assembly structure details and geometry colour information is retained during translation. Output file characteristics are configured using the standard PTC Recipe File Editor.

The Adapter may be installed on a number of machines each accessing a central network-floating license.

Primary Product Features

- Converts CATPart geometry including analytic data, solid models, and surfaces to the Creo View ".ol" file format
- Converts CATProduct assembly structure and part orientations to the Creo View ".pvs" file format
- Converts attribute data such as meta-data, colour and layer information and CATIA V5 properties
- Retains accuracy of data in Creo View allowing accurate measurements, sections etc.
- Converts CATDrawings to various 2D formats e.g DXF & TIF for viewing within Creo View
- Configuration compatible with other PTC Creo View Adapters
- Optional integration with Windchill, DIVISION Graphics Server as a standard "Worker" application. Also able to be integrated with other PDM environments
- Operates in both command-line and batch modes
-
- Configurable to output earlier versions of Creo View data
- Able to be initiated from within CATIA V5 menu system
- The Creo View data created using this Adapter can be imported into the Arbortext IsoDraw CADprocess

Primary Product benefits?

- Direct conversion from CATIA V5 to Creo View reduces processing time, simplifies integration and retains accuracy of the model
-
- Improved communication and collaboration by visualizing CATIA V5 data in Creo View across the enterprise
- Reduce costs and risks associated to accessing the wrong version of data by integrating the publishing process into all related business processes
- With over 20 years industrial use Theorem's product robustness and quality is well proven, reducing your business risk

This document will focus specifically on guidance for the use of The CATIA V5 Creo View Adapter. For information regarding any of Theorem's product ranges please contact sales@theorem.com

CATIA V5 to Creo View Adapter Product Modules

The following product modules are available for the Creo View Adapter:

Standard Product

The standard product functionality is detailed in this user guide and is available for use in a batch environments.

Standard Product for Windchill

The standard product for Windchill functionality is detailed in this user guide and is available for use in a batch and Windchill environments.

The following Service Modules require a prerequisite **'Standard Product for Windchill'** product baseline:

CATIA V5 to Creo View PMI Service Module

The PMI module allows PMI, Captures and View states to be read from CATIA V5 and written into Creo View.

CATIA V5 to Creo View Post Processing Service Module

The Post Processing module allows alternative formats ("Additional File Types") to be output alongside the standard Creo View output, via a single invocation. In addition bespoke post processing activities can be launched using this method.

CATIA V5 to Creo View JT Add On Service Module

The JT Add On module works independently of the Post Process module and allows a JT file to be created alongside assemblies and parts processed into Creo View.

CATIA V5 to Creo View 3D PDF Add On Service Module

The 3D PDF Add On module works independently of the Post Process module and allows a 3D PDF file to be created alongside assemblies and parts processed into Creo View.

CATIA V5 to Creo View Composites Add On Service Module

The Composites Add On module allows composites data from the specification tree to be created alongside assemblies and parts processed into Creo View. This requires a supporting CATIA composites license.

What's new in 24.0

Flexible Assembly Visualization

This release allows the end-user to make use of Flexible Assembly Visualization in Windchill. This behaviour is turned on by default in the CADVerter and flags are set that are activated in Windchill

Support for Contextual Parts contained in Flexible Assemblies con iare not supported in this revision of CADVerter

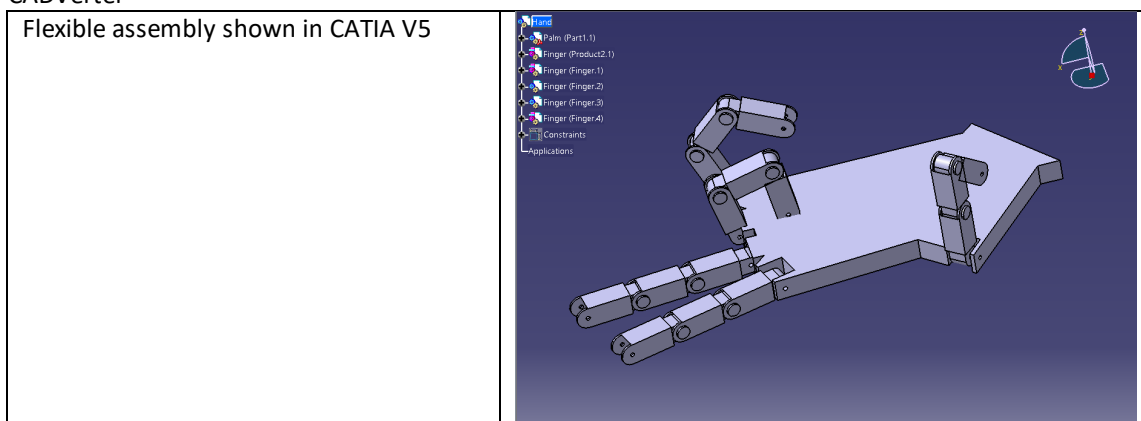

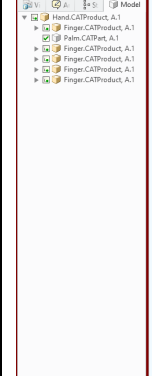
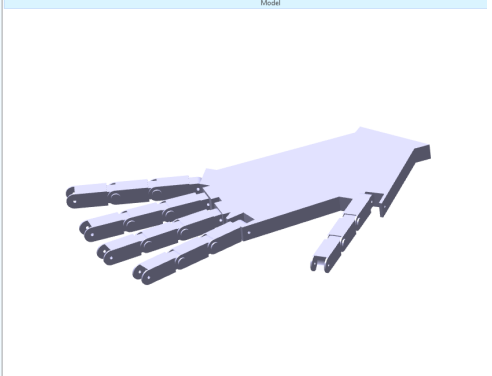
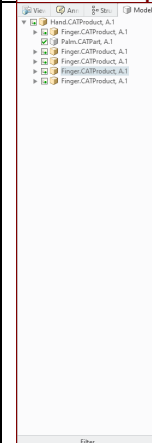
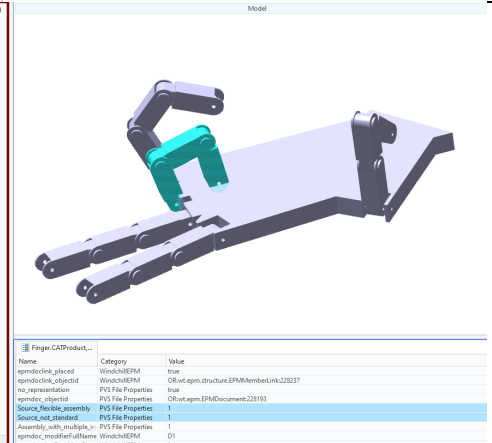
<p>Display in Creo View when value for "Flexible assembly features in Dymanic CAD Structures " is set to "No"</p>																																
<p>Display in Creo View along with attributes, when value for "Flexible assembly features in Dymanic CAD Structures " is set to "Yes"</p>		 <table border="1" data-bbox="847 943 1329 1055"> <thead> <tr> <th>Name</th> <th>Category</th> <th>Value</th> </tr> </thead> <tbody> <tr> <td>epmmlink_glned</td> <td>WindowEPM</td> <td>true</td> </tr> <tr> <td>epmmlink_objctid</td> <td>WindowEPM</td> <td>CR:ut.epm.structure.EPM/MemberLink:328237</td> </tr> <tr> <td>no_representation</td> <td>PVS File Properties</td> <td>true</td> </tr> <tr> <td>epmmlink_objctid</td> <td>PVS File Properties</td> <td>CR:ut.epm.EPM/Document:228193</td> </tr> <tr> <td>Source_File_in_assembly</td> <td>PVS File Properties</td> <td>1</td> </tr> <tr> <td>Source_not_standard</td> <td>PVS File Properties</td> <td>1</td> </tr> <tr> <td>Assembly_with_multiple</td> <td>PVS File Properties</td> <td>1</td> </tr> <tr> <td>epmmlink_fullname</td> <td>WindowEPM</td> <td>D1</td> </tr> <tr> <td>epmmlink_baseStructure</td> <td>WindowEPM</td> <td>False</td> </tr> </tbody> </table>	Name	Category	Value	epmmlink_glned	WindowEPM	true	epmmlink_objctid	WindowEPM	CR:ut.epm.structure.EPM/MemberLink:328237	no_representation	PVS File Properties	true	epmmlink_objctid	PVS File Properties	CR:ut.epm.EPM/Document:228193	Source_File_in_assembly	PVS File Properties	1	Source_not_standard	PVS File Properties	1	Assembly_with_multiple	PVS File Properties	1	epmmlink_fullname	WindowEPM	D1	epmmlink_baseStructure	WindowEPM	False
Name	Category	Value																														
epmmlink_glned	WindowEPM	true																														
epmmlink_objctid	WindowEPM	CR:ut.epm.structure.EPM/MemberLink:328237																														
no_representation	PVS File Properties	true																														
epmmlink_objctid	PVS File Properties	CR:ut.epm.EPM/Document:228193																														
Source_File_in_assembly	PVS File Properties	1																														
Source_not_standard	PVS File Properties	1																														
Assembly_with_multiple	PVS File Properties	1																														
epmmlink_fullname	WindowEPM	D1																														
epmmlink_baseStructure	WindowEPM	False																														

Multi Body Components

Multi-body components are now supported in Creo View and CADVerter takes advantage of this. The expand_part functionality will be replaced by this Multi-body support and is turned on by default. If this is not required it can be turned off in the recipe file.

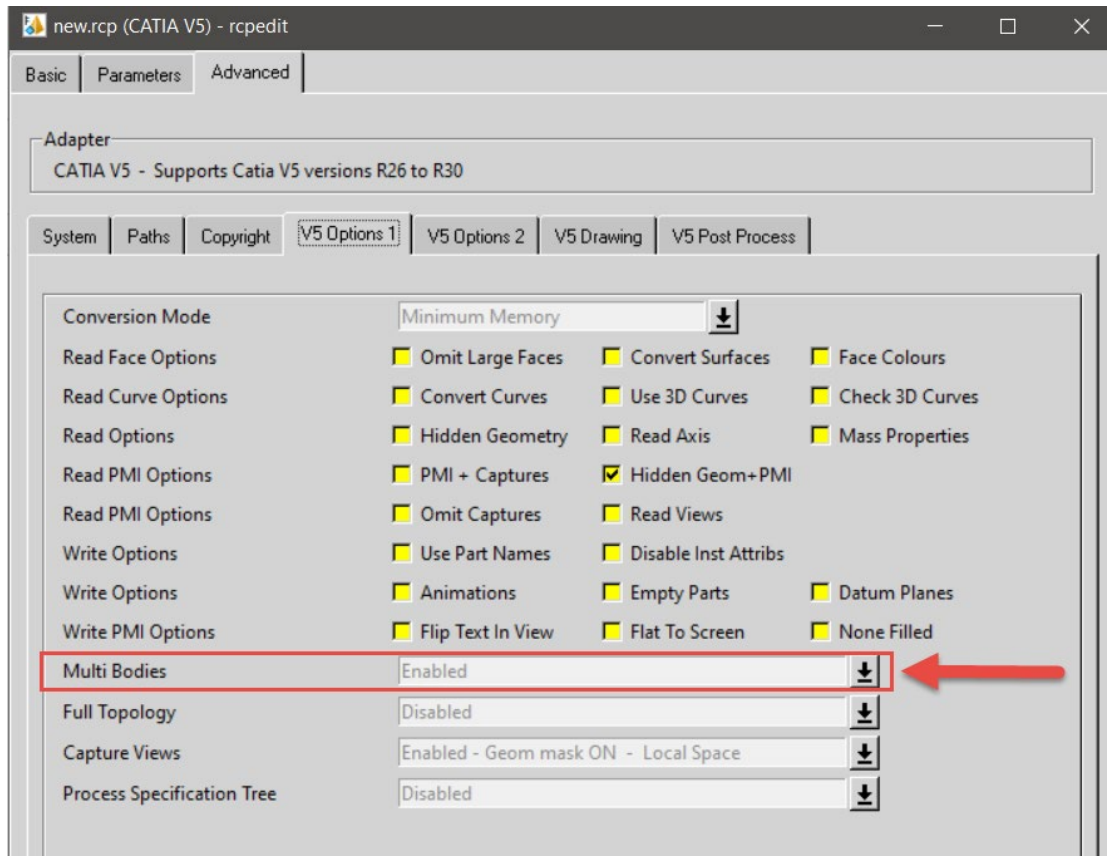

Each body will be shown with a new icon.  and can be individually addressed

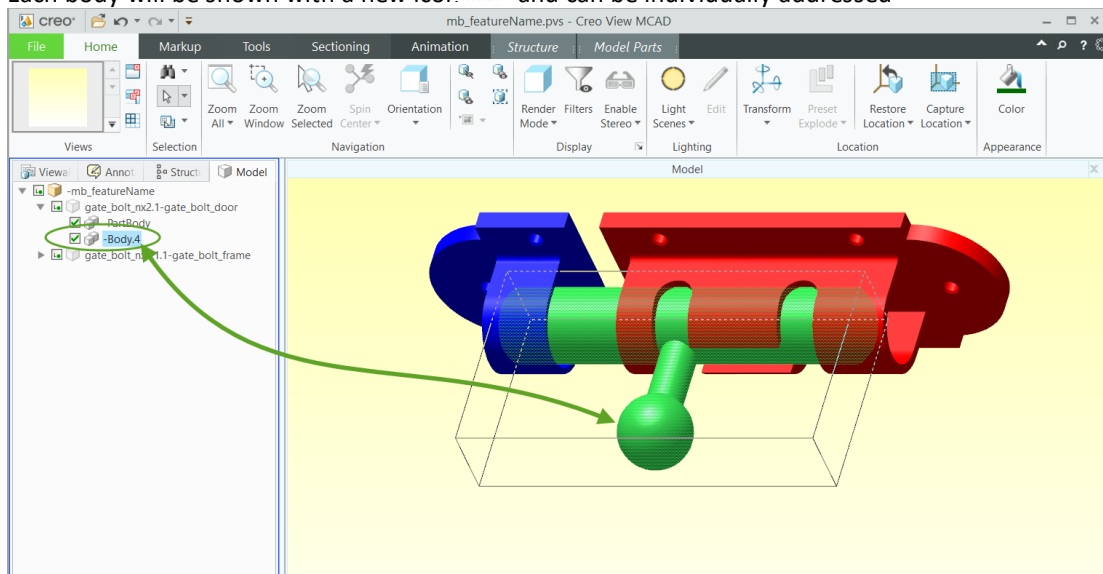

View State Comparison

A new Creo View tool, View State Comparison, will start to be supported by CADverter 23.4 and Creo View 7.1. It allows the PMI in each View State (CATIA Capture) to be compared, when two revisions of the same part are open.

A simple visual report of the two part revisions is clickable to allow each modification to be examined in more detail.

Further details of the View State Comparison tool can be found in the PTC Creo View documentation.

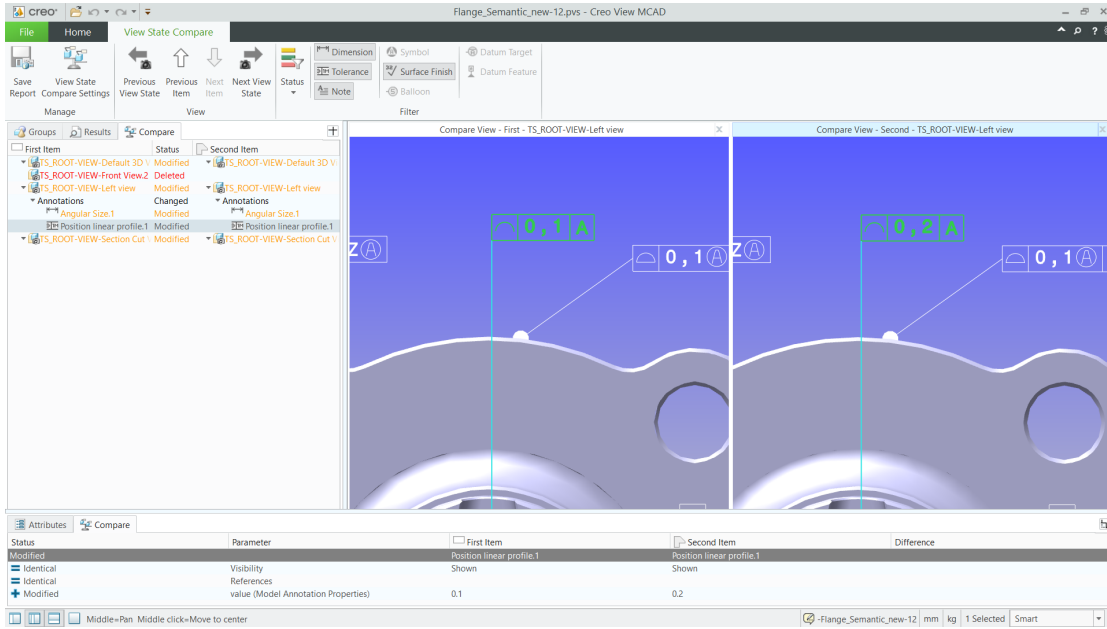

What's new in 24.2

Tessellation now uses default bounding box functionality

This release has moved the default tessellation strategy closer to that of PTC. The tessellation is based upon the solid and surface geometry bounds. In tests most cases have better or equal results than the previous revision. If there is any degradation in the tessellation in your particular case, please contact the support desk who will be able to help.

Materials and mass properties are read by default.

Materials and mass properties are now read by default when available. This will give more accurate mass property results in Creo View for single body and multibody components. Material properties only include colours but not texture maps. i.e. a material such as gold will have its colour mapped, whereas a material texture such as honeycomb will not.

Material visual properties (colour, opacity) are read.

Inheritance is also in place for multi-body components. At present the translator assumes the CATIA default, which is to propagate the material down to the lower level bodies. See examples below

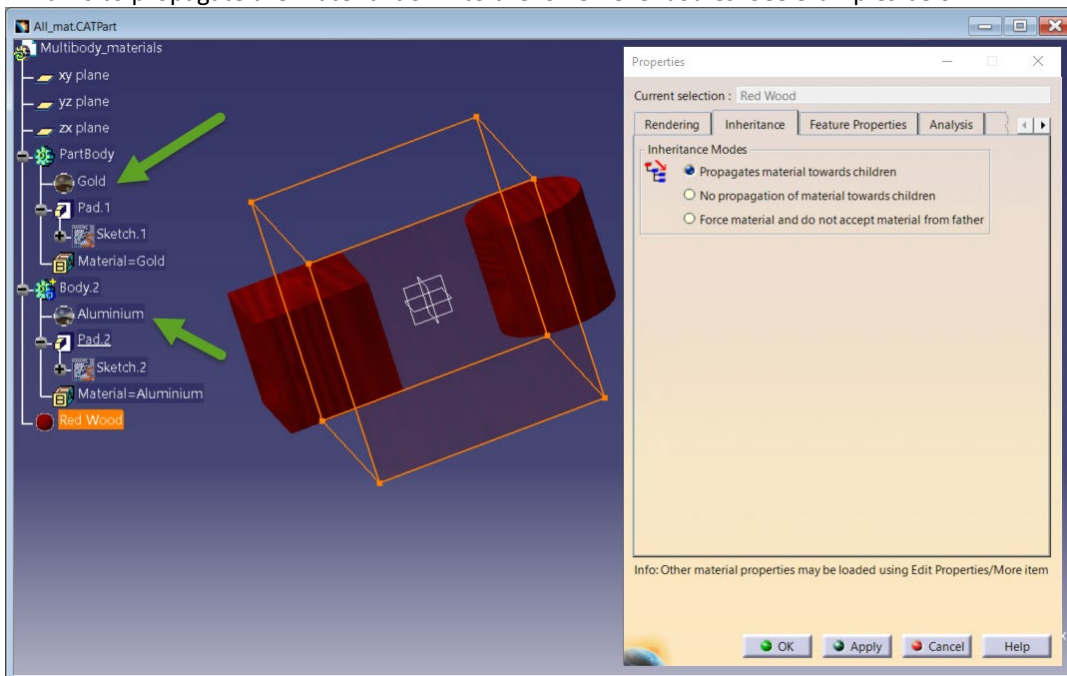

In the above example because Red Wood has a texture map applied then the translated output will be the default body colour. However the Part level mechanical properties will be correctly washed down to the lower level bodies.

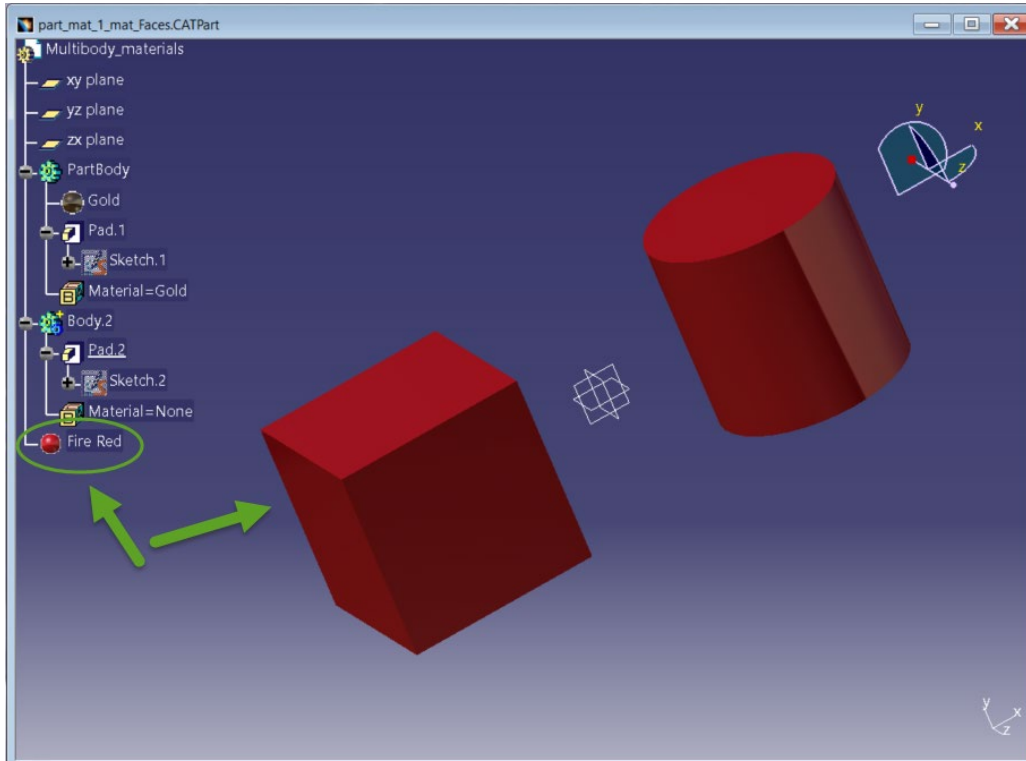

If a material with a colour, such as 'Fire Red' is applied then the colour will be translated as well as the mechanical properties.

Recipe File Changes

The Mass properties check box has now been removed from the V5 Options 1 tab of the Recipe Editor as this is now the default.

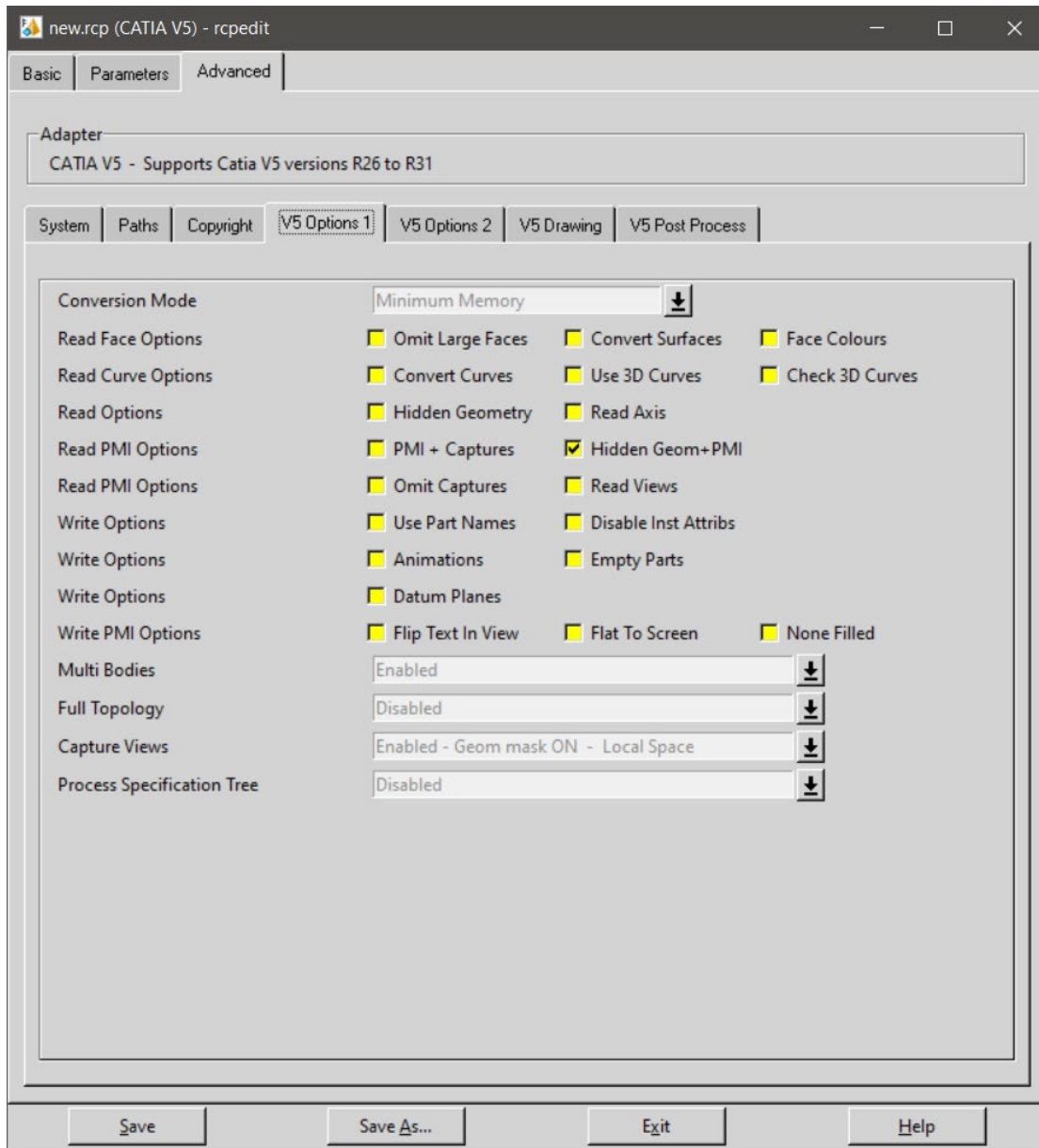

What's new in 25.2

CATIA V5-6 R2022 support

CATIA V5-6 R2022 is now supported

CGR Structures

CGR structures are now displayed consistently in both Standard and Minimum Memory mode

Enhancements to Material properties

There is now a button to override the material color rendering

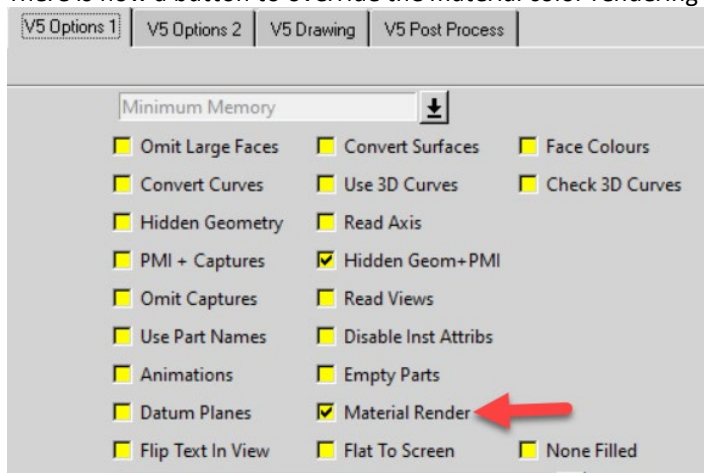

What's new in 25.4

Windchill Smart Platform Support: Locator Conversion

Starting from THEOREM 25.4.01 and WWGM 12.1.2.0 (Narwhal), it is possible to expose Locators information from CATIA V5 Adapter to Windchill for positioning visualization. These locators are used to position model variants within an assembly in Windchill.

In CATIA V5 terms a Locator is a 'named' Axis System e.g. as shown below 'LEFT_MOUNTED' or 'RIGHT_MOUNTED'

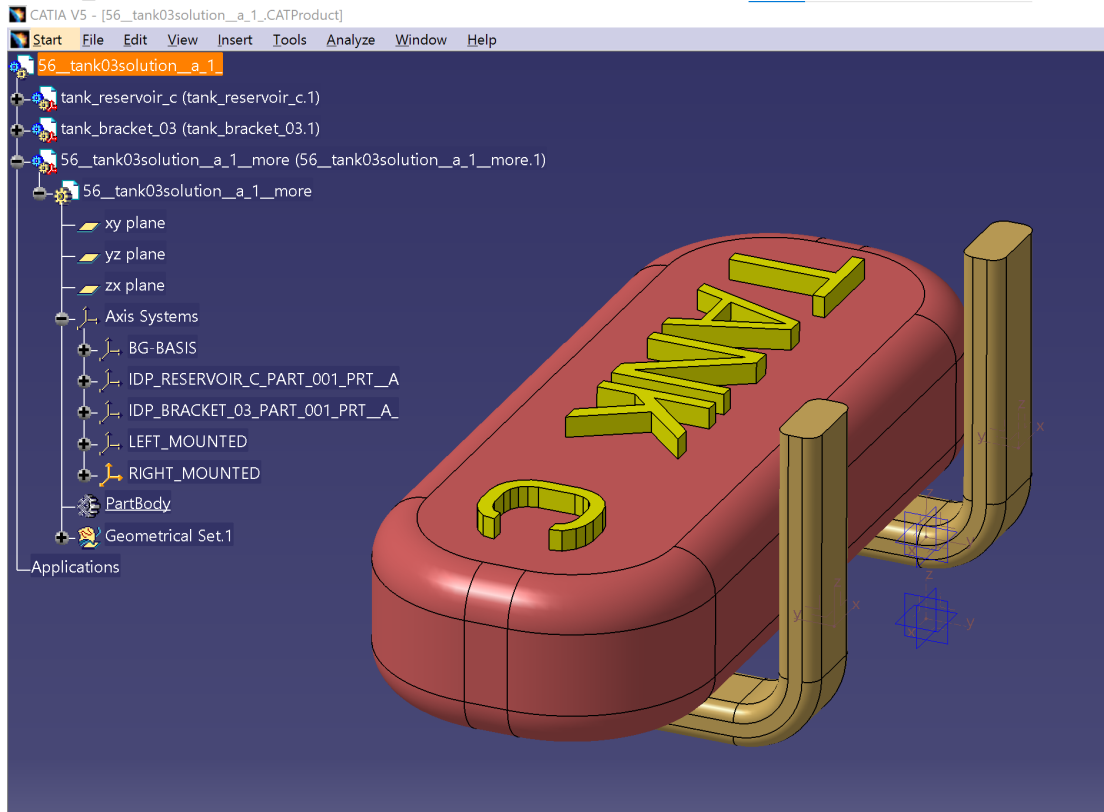

The process is then activated by setting two 'Filters'

File Filter

This allows the user to limit the parts which the translator will read to search for locators. This filter only applies to top level CATParts. The translator will not attempt to search lower-level parts for locators. This is important if the data is large with a flat structure as without this limitation many parts without locators will be read.

- The filter will allow a single asterix anywhere in the root string e.g. Skel* will find both Skeleton.CATPart and Skeleton_loc.CATPart or Skel*loc will only find Skeleton_loc.CATPart.
- Multiple parts can also be specified but these must be the full name e.g. Skeleton,Loc but not Skel*,*Loc.
-

File Locator Filter

- Multiple definitions can be in a comma separated list e.g., *TOR,L*3
- This will now allow a single asterix anywhere in the root string e.g., LOC*, *TOR or L*R will find a locator called LOCATOR.

Recipe File Changes

The two filters have been added to the recipe file as shown below.

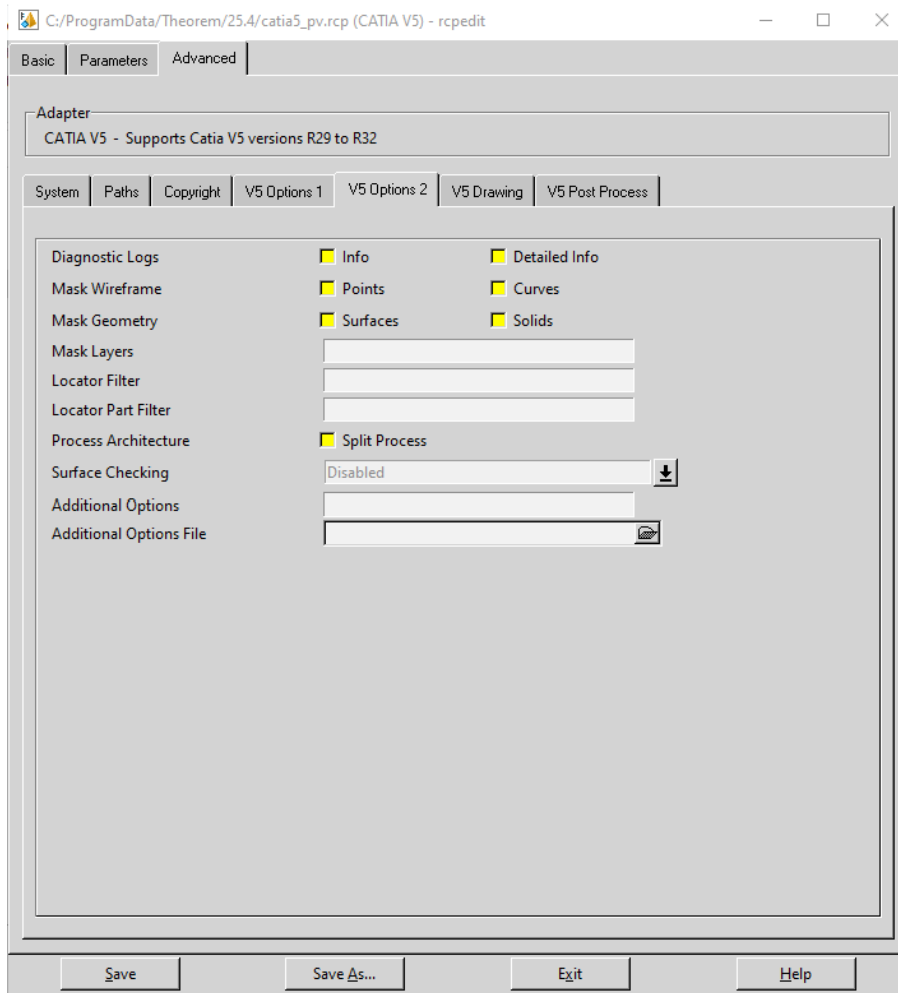

There are currently some known limitations.

- It is not possible to convert axis systems to locators using Minimum Memory mode.
- Publishing fails for a Product that contains an empty (without sketches or features) skeleton part.
- Users should set Additional Options to NOSHOW_AXIS (see below) on Worker Server to be able to expose hidden axis systems or axis systems with hidden references.

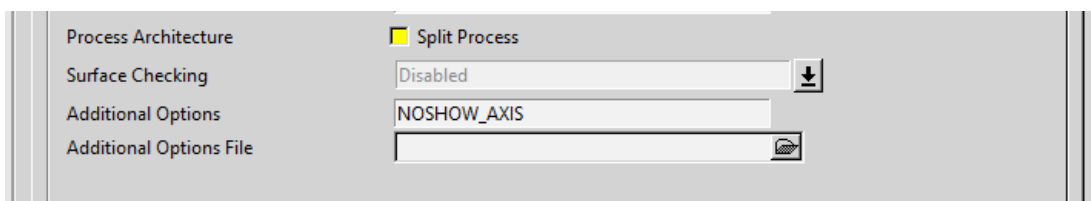

- Locator Filter and Locator Part Filter options do not recognize multiple " * " wildcard characters in their values.
- Deactivated axis system can be exposed to Windchill if its value matches the Locator Filter option.

What's new in 26.0

Quick View

QuickView for large assemblies is now available. Please refer to PTC article [CS381237](https://www.ptc.com/en/support/2023/07/CS381237) for further information.

What's new in 26.3

Multi-Body Parts and Materials

A reminder that the defaults for translation have changed over the last couple of revisions. Multi-body components are now read/created by default. This can be disabled in the recipe settings.



Materials are now read by default, the translator will also try to render the Creo View output using the CATIA material attributes. This can affect face colour display in the Creo View output. It is possible to turn this rendering off, so that body and face colours are rendered instead.

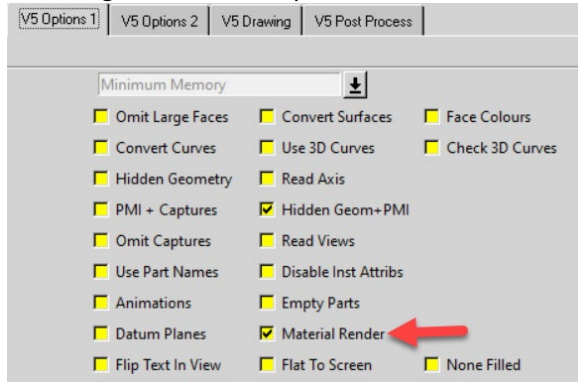

The translator will now always try to create mass properties for each body in a CATPart. For some parts (e.g. solids which have degraded to faces or a mixture of solids and surfaces) this can take a very long time without providing a useful mass properties result.

A new option MPROPS_OFF has been introduced to allow translation to take place more quickly.

Locators

A number of additional options/enhancements are now possible when using locators.

- Multiple Wildcards "*" are now recognised in Locator Filter and Locator Part Filter e.g. *LOC*
- Deactivated axis systems are no longer exposed as locators
- Empty skeleton Parts now publish successfully

What's new in 27.1

Print to Monochrome PDF

It is now possible to output PDF from a CATDrawing in monochrome. This needs a valid installation of Ghostscript which cannot be supplied by Theorem.

In most cases if Ghostscript has been installed in the default location, the translator will pick this up from the registry.

However in some cases Ghostscript may not be found even if a legitimate copy has been installed. In such a case please set the environment variable (see below)

```
set TS_GHOSTSCRIPT_INST=C:\Program Files\gs\gs10.02.0\bin
```

Here is what you should see after a successful run with Ghostscript installed...

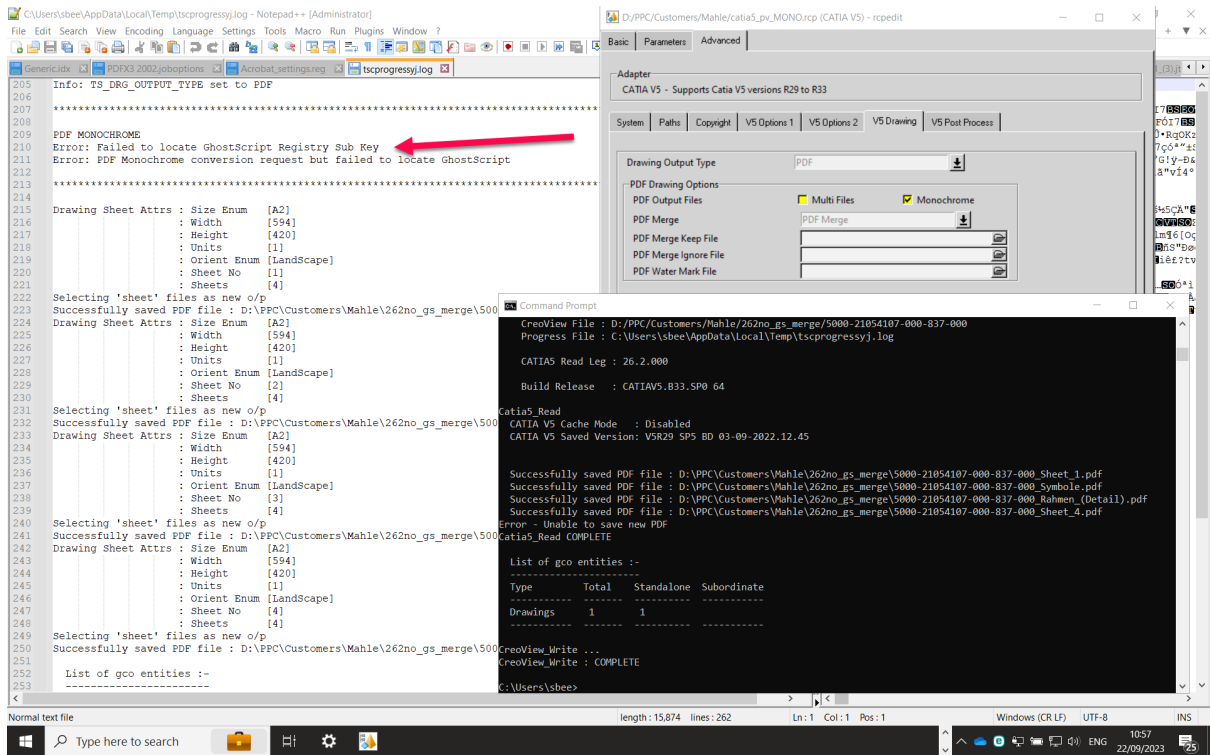

Info: TS_DRG_OUTPUT_TYPE set to PDF

PDF MONOCHROME

Error: Failed to locate GhostScript Registry sub Key

Error: PDF Monochrome conversion request but failed to locate GhostScript

Drawing Sheet Attrs : Size Enum [A2]
: Width [594]
: Height [420]
: Units [1]
: Orient Enum [Landscape]
: Sheet No [1]
: Sheets [4]

Selecting 'sheet' files as new o/p

Successfully saved PDF file : D:\PPC\Customers\Mahle\262no_gs_merge\5000-21054107-000-837-000

Drawing Sheet Attrs : Size Enum [A2]
: Width [594]
: Height [420]
: Units [1]
: Orient Enum [Landscape]
: Sheet No [2]
: Sheets [4]

Selecting 'sheet' files as new o/p

Successfully saved PDF file : D:\PPC\Customers\Mahle\262no_gs_merge\5000-21054107-000-837-000_Sheet_1.pdf

Drawing Sheet Attrs : Size Enum [A2]
: Width [594]
: Height [420]
: Units [1]
: Orient Enum [Landscape]
: Sheet No [3]
: Sheets [4]

Selecting 'sheet' files as new o/p

Successfully saved PDF file : D:\PPC\Customers\Mahle\262no_gs_merge\5000-21054107-000-837-000_Symbol.pdf

Drawing Sheet Attrs : Size Enum [A2]
: Width [594]
: Height [420]
: Units [1]
: Orient Enum [Landscape]
: Sheet No [4]
: Sheets [4]

Selecting 'sheet' files as new o/p

Successfully saved PDF file : D:\PPC\Customers\Mahle\262no_gs_merge\5000-21054107-000-837-000_Rahmen_Detail.pdf

Drawing Sheet Attrs : Size Enum [A2]
: Width [594]
: Height [420]
: Units [1]
: Orient Enum [Landscape]
: Sheet No [1]
: Sheets [4]

Selecting 'sheet' files as new o/p

Successfully saved PDF file : D:\PPC\Customers\Mahle\262no_gs_merge\5000-21054107-000-837-000_Sheet_4.pdf

Error - Unable to save new PDF

Catia5_Read COMPLETE

List of gco entities :-

Type	Total	Standalone	Subordinate
Drawings	1	1	

CreoView_Write ...
CreoView_Write : COMPLETE

... and if Ghostscript is not found...

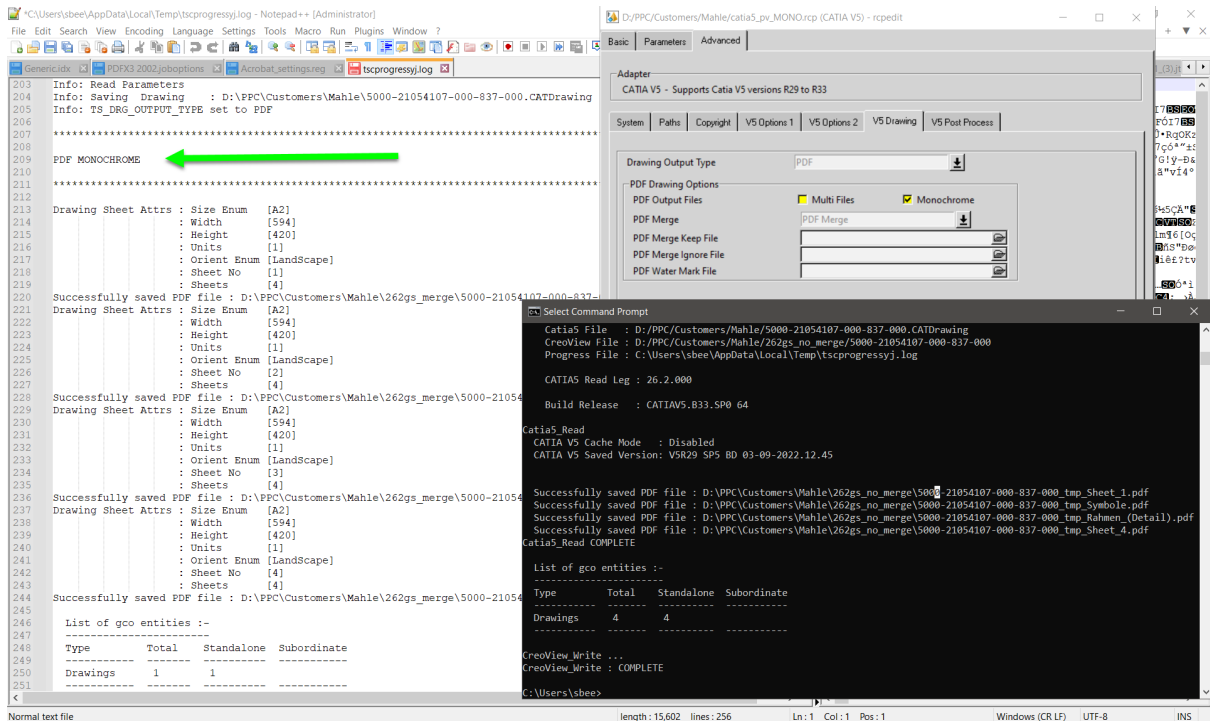

Info: Read Parameters

Info: Saving Drawing : D:\PPC\Customers\Mahle\5000-21054107-000-837-000.CATDrawing

Info: TS_DRG_OUTPUT_TYPE set to PDF

PDF MONOCHROME

Drawing Sheet Attrs : Size Enum [A2]
: Width [594]
: Height [420]
: Units [1]
: Orient Enum [Landscape]
: Sheet No [1]
: Sheets [4]

Successfully saved PDF file : D:\PPC\Customers\Mahle\262gs_merge\5000-21054107-000-837-000

Drawing Sheet Attrs : Size Enum [A2]
: Width [594]
: Height [420]
: Units [1]
: Orient Enum [Landscape]
: Sheet No [2]
: Sheets [4]

Successfully saved PDF file : D:\PPC\Customers\Mahle\262gs_merge\5000-21054107-000-837-000 tmp_Sheet_1.pdf

Drawing Sheet Attrs : Size Enum [A2]
: Width [594]
: Height [420]
: Units [1]
: Orient Enum [Landscape]
: Sheet No [3]
: Sheets [4]

Successfully saved PDF file : D:\PPC\Customers\Mahle\262gs_merge\5000-21054107-000-837-000 tmp_Symbol.pdf

Drawing Sheet Attrs : Size Enum [A2]
: Width [594]
: Height [420]
: Units [1]
: Orient Enum [Landscape]
: Sheet No [4]
: Sheets [4]

Successfully saved PDF file : D:\PPC\Customers\Mahle\262gs_merge\5000-21054107-000-837-000 tmp_Rahmen_Detail.pdf

Drawing Sheet Attrs : Size Enum [A2]
: Width [594]
: Height [420]
: Units [1]
: Orient Enum [Landscape]
: Sheet No [1]
: Sheets [4]

Successfully saved PDF file : D:\PPC\Customers\Mahle\262gs_merge\5000-21054107-000-837-000 tmp_Sheet_4.pdf

Catia5_Read COMPLETE

List of gco entities :-

Type	Total	Standalone	Subordinate
Drawings	4	4	

CreoView_Write ...
CreoView_Write : COMPLETE

Getting Started

Documentation

The latest copy of this documentation can be found on our web site at:

<http://www.theorem.com/Documentation>

Each product has a specific link that provides user documentation in the form of PDF and Tutorials videos.

Installation Media

The latest copy of Theorem software can be found via our web site at:

<http://www.theorem.com/Product-Release-Notes>

Each product has a specific link to the Product Release Document, which contains a link to the download location of the installation .msi.

Alternatively, you can request a copy of the software to be shipped on a physical CD.

Installation

The installation is run from the .msi file download provided.

To install the translator, select the **right click** the msi package file and select install. More information can be found in the 'Installation and Configuration Guide' located [here](#).

License Configuration

In order for the translation to run successfully, the Theorem license file provided to you needs to be configured using FlexLM. For a full guide to this process, please see our 'Installation and Configuration Guide' located [here](#).

Running the Product

Once configured and licensed, the product is ready to be run.

Prior to running the product CATIA V5 must have been started at least once to allow CATIA V5 licenses to be accessed. All specific CATIA V5 environment configuration details are documented in [Appendix A](#) of this document.

There are 3 distinct ways of running the translator:

- Via the Command Line
 - The Command Line Interface provides a direct method of invoking the translator. It can be used directly on the command line or called via a third party application as part of a wider process requirement. Full compatibility with PTC's Windchill Visualization Service (WVS) is supported and is detailed in PTC's *Windchill Installation and Configuration Guide Catia5_CreoView*.
 - For a full guide to this process, please see our 'How to Translate CATIA V5 to Creo View via the Command Line' later in this document
- Using the Theorem UI
 - The product can be run Independently in the Theorem Unified Interface. This allows the user/administrator to create specific named configurations for translating different types of data to achieve the best results
- Interactively from within CATIA V5

- The Interactive Interface provides a direct method of Translating CATIA V5 data to Creo View from within CATIA V5 itself, using add-Ins to the CATA "Save As" menus

For a full guide to this process, please see our 'How to Translate CATIA V5 to Creo View via Interactive mode' later in this document

Using the Product

Translation Configuration

It is recommended that the CATIA V5 to Creo View Adapter be run from a pre-created configuration. Theorem have adopted the standard PTC Configuration tools which will create a **batch** script for running the Adapter on the command line and also a **worker** script to allow the Adapter to be run with Windchill.

- For full details of this process, please see our 'How to Configure the CATIA V5 to Creo View via CADverter' later in this document

To take full advantage of the configuration tools and to configure the Adapter for use as a Windchill Worker please contact your PTC representative to provide the *Windchill Installation and Configuration Guide Catia5_CreoView*.

Default Translation

Default Translation – via the Command Line

Running a translation via the command line can be carried out without using a pre-created configuration. This will use the default translator settings. This is achieved by directly running the script file located in the **<installation_directory>\bin** directory. The format of the command is as follows (Note! Replace the [XX] seen in the example with the version of CATIA V5 you are using. E.g. for V5 R24, change to 24):

<Translator_installation_directory>\bin\catia5rXX_pv.cmd <input_files> -p <output_path> -o <output_file>

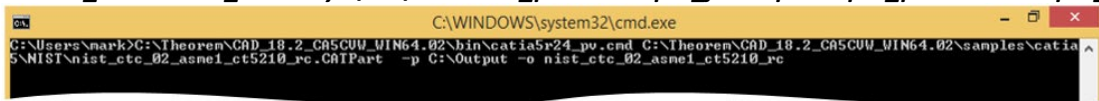

```
C:\WINDOWS\system32\cmd.exe
C:\Users\nark>C:\Theorem\CAD_18.2_CASCUW_WIN64.02\bin\catia5r24_pv.cmd C:\Theorem\CAD_18.2_CASCUW_WIN64.02\samples\catia5\NIST\nist_ctc_02_asne1_ct5210_rc.CATPart -p C:\Output -o nist_ctc_02_asne1_ct5210_rc
```

The example above will translate a sample file provided within the installation and produce the following screen output:

```
Sourcing Theorem Environment from :-
C:\Theorem\CAD_18.2_CA5CUW_WIN64.02\bin\..\ts_env.bat
Setting run time environment please wait ...
Using TS_INST = C:\Theorem\CAD_18.2_CA5CUW_WIN64.02
using CATIAU5_INST = C:\cad_apps\catia\v5r24_p3_complete\B24
Using Platform win_b64
Launching translation please wait ...
Catia5_Access ...
Catia5_Access COMPLETE
MOTION      option license available
SRFCHK      option license available
U4          option license available
U4MAIN      option license available
SCAN        option license available

*****
* Copyright Theorem Solutions Limited
* Catia5 - CreoView Creo 3.0 - M030 (13.2.30.38) CADverter Version 18.2.002 *
*****

Tue Jun 02 18:23:48 2015

Input
Catia5 File   :
C:\Theorem\CAD_18.2_CA5CUW_WIN64.02\samples\catia5\NIST\nist_ctc_02_asme1_ct5210_rc.CATPart
CreoView File : C:\Output\nist_ctc_02_asme1_ct5210_rc
Progress File  : C:\Users\mark\AppData\Local\Temp\tscprogressyj.log

CATIA U5 Library Ver. : 18.2.002
CATIA U5 Build Release: B24.SP0 64

Catia5_Read
CATIA U5 Cache Mode   : Disabled
CATIA U5 Env Name     : TheoremCatia5R24
CATIA U5 Env Dir      : C:\Users\mark\AppData\Roaming\DassaultSystemes\CATEnv
CATIA U5 Saved Version: U5R21 SP3 BD 01-11-2012.20.00

Catia5_Read COMPLETE

List of gco entities :-
-----
Type          Total      Standalone  Subordinate
-----
Points        8           8           0
Arcs          452         0           452
Conics        4           0           4
Lines        689         1           688
Curves       368         0           368
Surfaces     154         0           154
Cones        158         0           158
Cylinders    228         0           228
Planes       129         0           129
Faces        669         0           669
Edges       1513         0           1513
Vertices     942         0           942
Bsolids      1           1           0
-----

CreoView_Write ...
CreoView_Write : COMPLETE
```

C:\Output\nist_ctc_02_asme1_ct5210_rc.pvs

The above example provides the minimum command line arguments required to create an output. In order to support the PTC Windchill interface, Theorem have also adopted the PTC Adapter command line syntax, a full list of available options is shown below and can be displayed by issuing the following command:

<Translator_installation_directory>\bin\catia5rXX_pv.cmd -h

Setting	Result
<@File>	Read Options from the response file <file>
-?-h	For basic help page. UNIX may try to export the "?" so -h should be typed in quotes, "h".
-d <depth>	Set the conversion file depth. When converting an assembly file determines to what depth the hierarchy should be traversed. The default is all.
-H	For extended help options
-o<name>	Set output file base name (number of input files must be 1).
-p<name>	Set output base path.
-r<name>	Set recipe to <name>
-vc	Disable all console print-out.
-vc1	Redirect all console print-out to stdout.

-vc2	Redirect all console print-out to stderr (default)
-ve[n]	Increment or set (if[n]is given) the error reporting level. –ve0 disables all error reporting, default 1.
-vl<file>	Direct all printed output to <file>
-vL<file>	Concatenates all printed output to <file>
-vn<file>	Direct all printed output to new log file <file>-#.log.
-vp<n>	Set the process verbosity flag. List the modules by –l. Flags are listed in the source code.
-vw[n]	Increment or set the warning reporting level, see -vc
-vt	Give the current date/time stamp with all print outs.
-j<name>	Get job from <name> .paj file
-epdconnect	Enable EPD.Connect orientated conversion.
-mockup	Enable MockUp oriented conversion process

Configuring the CATIA V5 Creo View Adapter using the Recipe Editor

Full details of how to Configure the CATIA V5 Creo View Adapter is contained later in this document

This section of the User Guide describes the available configuration options provided by the recipe editor.

A recipe is a set of user-defined rules that drive the individual CAD Adapter. The recipe concept provides a solution to the problem of efficiently converting CAD data into a form suitable for viewing on a wide range of computer platforms. Like its analogy in cooking, gaining a desired result requires cooking to a specific recipe. While most CAD parts will convert into an efficient form for large-scale visualization, some parts require modifications to the standard visualization recipe to be viewed effectively.

The CATIA V5 Adapter is provided with a master or default recipe file. This file is pre-configured to allow the visualization of most objects. The master recipe file should not be edited. Instead, additional new recipes can be created from this default file using Save As function in the recipe editor (***rcpedit***) provided with the translator.

For full details concerning the Recipe Editor, please refer to the '*Creo View MCAD Adapters Installation and Configuration Guide*' document, which can be obtained via the PTC Reference Documents Site at <https://www.ptc.com/appserver/cs/doc/refdoc.jsp>. Theorem's Creo View Adapters use the standard PTC mechanism to Configure translation options. The basic concepts and available options are covered here for convenience.

Theorem provide a configuration script to allow a recipe file to be created. Running the following script will launch the Recipe Editor Configuration Tool:

<Translator_installation_directory>\bin\catia5_pv_config.cmd

The panel below will be displayed:

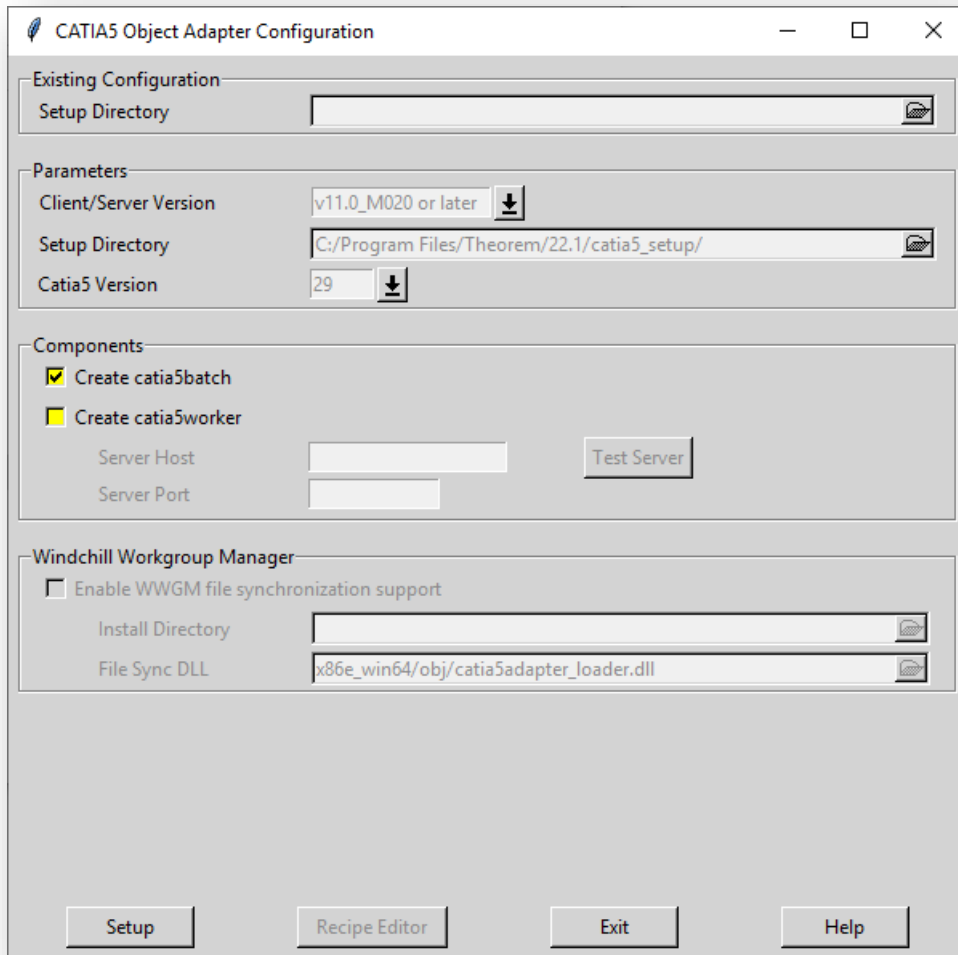

The Configuration Tool allows the CATIA V5 Creo View Adapter to be configured for use in batch (*via the command line*) and/or for use in a Windchill environment (*catia5worker*). Please contact your PTC representative to provide the *Windchill Installation and Configuration Guide Catia5_CreoView* for full details on configuring in a Windchill environment. This guide will focus on running the translator from the command line, but all of the configuration options are available in both environments.

The **'Create catia5batch'** selection will create a recipe file for batch and the **'Create catia5worker'** will create a recipe file for a Windchill invocation. Having selected either of these options (and provided a valid Windchill Host and Port) the **'Setup'** button will become active. Selection of the **'Setup'** button will launch the following panel:

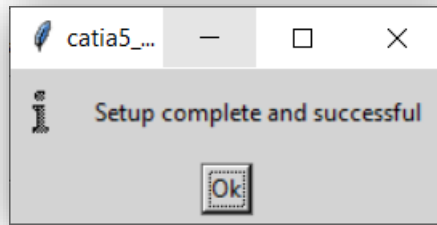

This can be accepted and the **'Recipe Editor'** button will become active.

The **'Setup'** action will create a new directory beneath the translator installation directory. So, the user that creates new configurations will need write access to the translator installation directory. The first configuration directory will be named **catia5_setup**. Subsequent configurations will be named **catia5_setup'n'** (where 'n' is a unique number). In this manner many different configurations can be created. The configuration directory will contain an invocation script that will deliver a default Configuration that uses default translation settings. Selection of the **'Recipe Editor'** button will allow the user to set specific translation settings.

The contents of a Configuration folder are:

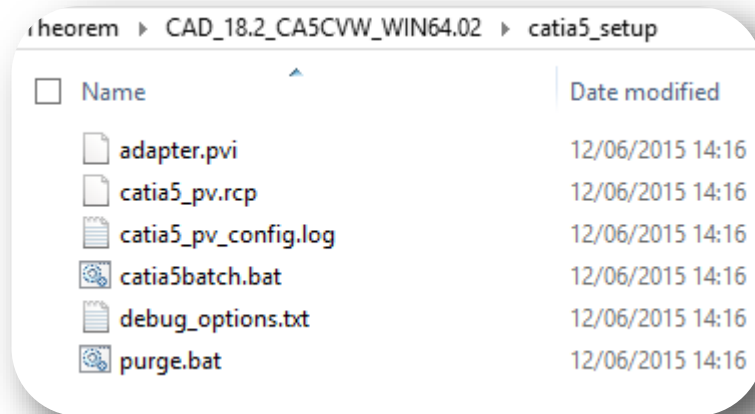

The **catia5batch.bat** script will be used in preference to the Theorem provided script discussed in the Default Translation – via the Command Line section and will use configuration options specified in the **catia5_pv.rcp** (recipe) file.

Running a translation using the **catia5batch.bat** script can be achieved using the following command

```
<Translator_installation_directory>\catia5_setup\catia5batch.bat <input_files> -p <output_path> -o <output_file>
```

The results and screen output will be the same as that noted for the Default Translation.

Changing the translation options in the configuration recipe file is achieved by selecting the 'Recipe Editor' button.

This action will display a number of panels that are of interest to the Theorem CATIA V5 Creo View Adapter.

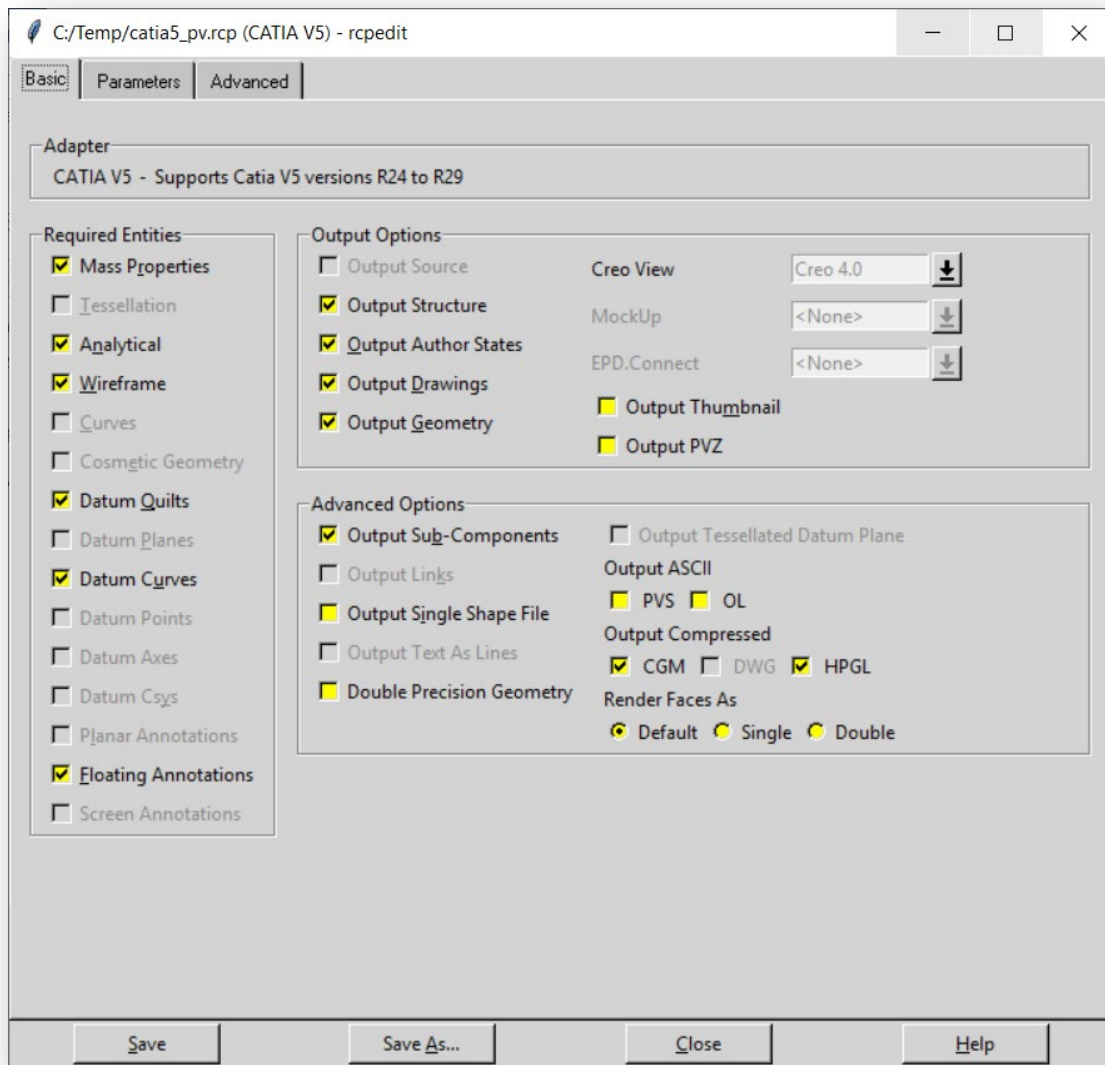

The main page provides standard PTC options that we will not discuss in this document, as these are well documented in PTC's 'Creo View MCAD Adapters Installation and Configuration Guide' document, which can be obtained via the PTC Reference Documents Site at <https://www.ptc.com/appserver/cs/doc/refdoc.jsp>. Instead, we will focus on the Theorem specific settings that effect the output. These are accessible via the **Advanced Tab** and are grouped into 4 sub pages:

- V5 Options 1 – General translation settings (including PMI)
- V5 Options 2 – more translation settings
- V5 Drawing – Options relating to CATDrawing processing
- V5 SaveAs – Options relation to the post process and SaveAs translation behaviour

V5 Options 1 – General translation settings (including PMI)

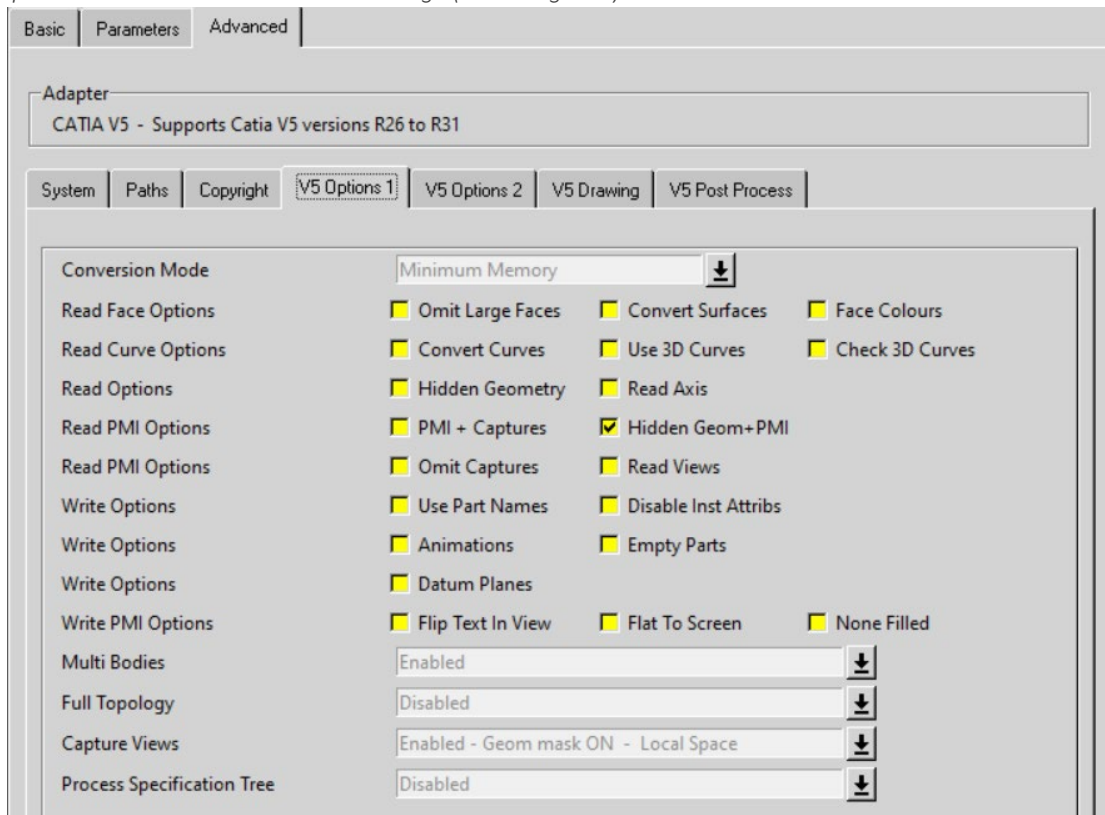

Each of these options is described below:

Option	Description	
Conversion Mode	<p>The user has the option to process Assembly information in one of 2 modes:</p> <ul style="list-style-type: none"> • Minimum Memory • Standard <p><i>Minimum Memory:</i> The default method for assembly processing and a more efficient way of processing the data is provided via the Minimum Memory conversion mode selection. This mechanism reads in the assembly data then processes each “.CATPart” file referenced by the assembly on a part by part basis.</p> <p><i>Standard:</i> This reads a CATIA V5 assembly and its entire geometry contents into memory, before writing out all of the data to Creo View.</p> <p><i>See the section on Assembly Processing Best Practises for more info.</i></p>	
Read Face Options	Omit Large Faces	Allows the user to omit large PLANEs where the bounding exceeds 0.1Km in any direction. These faces are most often construction planes. The bounding box size can be adjusted by using the additional argument set_omit_large_planes <value in M> , see additional options for details.
	Convert Surfaces	Allows the CATIA V5 API to convert analytical surfaces as NURBs, this may be useful from time to time if face/surface

Read Curve Options		errors occur in the CATIA V5 read. (Often used in along with Convert curves)
	Face Colours	By default individual face colours are not read, this option enables individual face colours to override solid colours.
	Convert Curves	Allows the CATIA V5 API to convert analytical curves as PCURVES, this may be useful from time to time if edge/curve errors occur in the CATIA V5 read. (Often used in along with Convert surfaces)
	Use 3D Curves	This option allows Creo View API to generate its own 2D curves. This option is most likely only ever used as a work-around when poor data is encountered.
General CATIA V5 Read	Check 3D Curves	This option allows the Adapter to test the data and if necessary automatically enable Use 3D Curves. A default tolerance of 0.01 (1%) face/surface overlap being used for these checks. This tolerance can be adjusted with <i>validate_3D_curve_tol <value></i> in the additional option field.
	Hidden Geometry	Allow the translation of hidden nodes
	Read Axis	Enables the reading of CATIA V5 axis systems.
PMI Read Options	PMI + Captures	<i>Please note!</i> This feature will require additional Theorem licenses. See the ‘CATIA V5 to Creo View with PMI’ demonstration video for full details. Enables the read of PMI stroked and semantic data. Reading of captures is automatically enabled.
	Hidden Geometry + PMI	Optionally read PMI Annotation set construction geometry
	Omit Captures	Reads only the Views if the option below is checked
	Read Views	Optionally read views, when reading PMI
Creo View Write Options	Use Part names	Use the CATIA V5 'part number' names for assembly nodes. The default is to use 'Instance name'.
	Disable Inst Attribs	Disables the output of any instance attributes.
	Animations	<i>Please note!</i> this feature will require additional Theorem licenses. Outputs one or more .fra animation files, which can be imported into any Creo View viewer that supports animations. The .fra files will be created alongside the output .pvs file, in the same location and with the same base name. If the animation has a title (name) this will be appended to the base name, for example : <i>C:\TEMP\chainsaw.pvs</i> Will result in: <i>C:\TEMP\chainsaw_removeCover.fra</i> The .fra files are created by default in mm.
	Empty Parts	Creates an empty (contains a single point at X0,Y0,Z0) dummy .ol file for empty nodes, to force the geometry node creation, where no geometry exists

PMI Filters	Datum Planes	<p>Allows large planes, that are by default omitted, to be written as Datum Planes. Selecting this option will replace PLANES where the bounding box diagonal exceeds 0.1Km with a Datum PLANE 35mm square. The bounding box size can be adjusted by using the additional argument <i>set_omit_large_planes <value in mm></i></p> <p>If the size of the created datum PLANE can be adjusted by using the additional argument <i>set_create_datum_planes <value in mm></i>, see additional options for details.</p>
	Flip Text In View	NOA data read from CATIA V5 may be flipped so that it is readable from any given capture view. This option adjusts the text to mimic the behaviour of the CATIA V5 application.
	Flat To Screen	<p>Text And NOA data read from CATIA V5 that is 'flat to screen' will be written 'flat to screen' with this option set. In order for this option to work, the semantic PMI MUST be read, which means the Read PMI option MUST be set to Enabled.</p> <p>Please note that these entities are Floating Markup in the Creo viewer. In order to see them in the viewer these entities should be 'enabled' (see <i>MODEL ANNOTATIONS NAVIGATION FILETRS panel in the Creo Viewer and ensure FLOATING ANNOTATIONS is selected</i>)</p> <p>It also it may be necessary the select floating annotations and (Right Mouse Button) select 'show' to see them in Creo viewer.</p>
	None Filled	Disable the writing of filled (solid) arrow heads and text, as read from CATIA V5. Only provide an outline style
Full Topology		Controls how the topology is written into Creo View data. By default this is 'disabled', which is consistent with earlier releases of the product. The default setting generates good viewable data, but since each face of a solid is written separately it is not possible to calculate mass properties such as volume, correctly view capping sections or perform 3D Compare or Interference Detection in the Creo View client.
	Disabled	<i>(Default setting)</i> Solid faces written with unique edges.
	Enabled	<p><i>(Solids only)</i> – Adjacent faces share edges, such that the resulting Creo View data can support mass properties etc.</p> <p><i>(Solids & Quilts)</i> – Adjacent faces share edges, this includes 'open solids', which will be written into Creo View as quilts.</p> <p><i>(Solids only)</i> Fix non-manifold - As above with additional behaviour needed to resolve non-manifold conditions caused by CATIA V5 add operations.</p> <p><i>(Solids & Quilts)</i> Fix non-manifold – Both solids and open solids processed and resolve non-manifold conditions caused by CATIA V5 add operations.</p>

		<p>NOTE! Enabling full topology can increase translation times, so we suggest that the user selects the minimum setting that required. For example, don't use the Fix non-manifold settings unless necessary and don't use the Quilts setting unless required.</p>
Capture Views		<p>Allows control over the processing of any PMI capture data. Please Note! The following limitations apply: to correctly view captures with Theorem's v14.1 (onwards) translator it is necessary to use CreoView 1.0 M020 or later Options are:</p>
	Disabled	Do NOT write captures
	Enabled	<p>Geom Mask ON – Local Space : (Default setting) This will ensure that only the geometry associated with a given capture view is displayed in that view. Geom Mask OFF – Local Space : Allow user to have all geometry displayed in every capture view. Geom Mask ON – Global Space : Geom Mask OFF – Global Space Points to note are :</p> <ul style="list-style-type: none"> • Local Space presents the view relative to the geometry at the assembly node (Consistent with CATIA V5 up to and including R19) • Global Space transforms the view into Global or World view (Consistent with CATIA V5 since R19) • Any Hidden PMI will automatically be read when captures are enabled, however the user should enable the Hidden Geometry option if they wish to include this data in the captures
Process Specification Tree		<p>Please note! this feature will require additional Theorem licenses. Allows Model Based Definition (MBD) data to be read. Options are:</p>
	Disabled	(Default setting) do not read the specification tree (MBD).
	Enabled	<p>The specification Tree setting will provide a true representation of the Geometry and PMI entities in the capture views when used in conjunction with the setting: Capture views = Enabled – Geom Mask ON</p>
	Enabled - Expanded	<p>The specification Tree is read to a deeper level which supports the 'initial view state' of views - please note this option can produce many more output files.</p>

V5 Options 2 – more translation settings

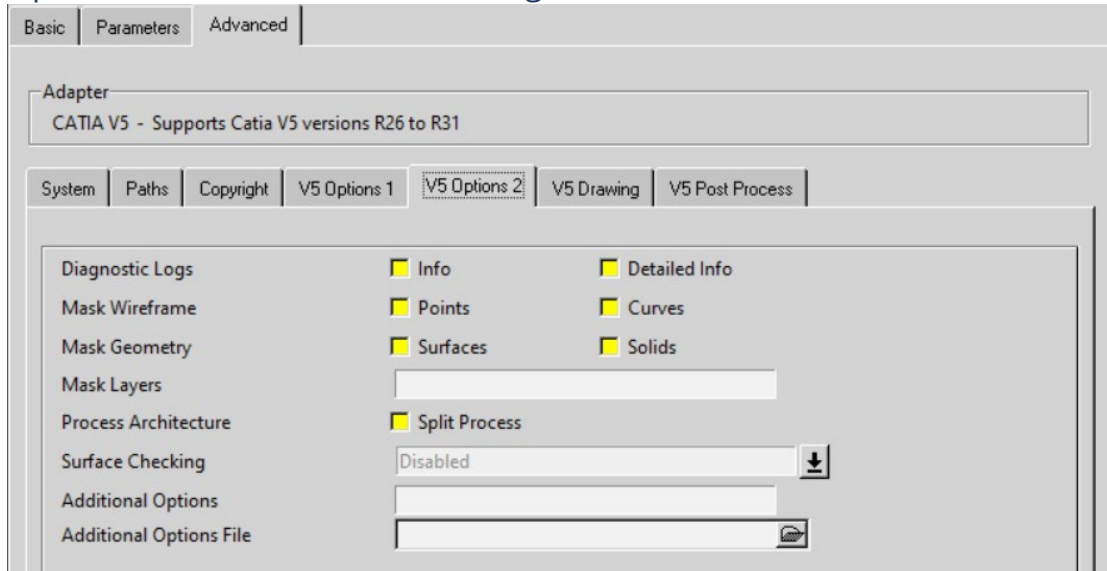

Each of these options is described below:

	Option	Description
Diagnostic Logs	Info	Generate a more verbose log files
	Detailed info	Used as a diagnostics level of detail in the log file <i>(for debug purposes only)</i>
Mask Wireframe	Points	Turn off Point processing. By default points are translated.
	Curves	Turn off Wireframe Curve processing. By default curves are translated.
Mask Geometry	Surfaces	Turn off Surfacing processing. By default curves are translated.
	Solids	Turn off Solid processing. By default solids (or Breps) are translated.
Mask Layers		By default, ALL layers are translated. This field allows the user to select which layers ARE translated.
	To translate specific layers	The syntax for this field is limited to ranges of layer numbers (separated by '-') and individual layer numbers; each range and individual number being separated by a comma ','. e.g. 20-30,45,100-300 Means layers 20 through to 30 AND 45 AND 100 through to 300 WILL be translated. <i>The full range of layers is 0-1023</i>
Process Architecture	Split Process	This option may aid some specific data issues BUT it should only be used with guidance by Theorem support.

Surface Checking	<p>The default is disabled.</p>	<p>Generates a report file that details any points on the output Creo View surfaces that deviate by a distance greater than a selected tolerance.</p> <p>Also, optionally, the output Creo View data can be annotated with 'surface check' points to indicate where these points are. This is achieved by selecting one of the tolerance suffixed with (<i>plot points</i>).</p> <p>The 'surface check' points are coloured green for within selected tolerance and red for outside selected tolerance.</p> <p>The report file is created alongside the Theorem progress file and will be named "<progress_name>_surf_check.log". A report summary will be created as follows:</p> <pre> SURFACE CHECKING COMPLETE PLEASE CHECK : Some Surface check issues Found [4434] points <= Gap Tol (green points) [0.001] Found [1544] points > Gap Tol (red points) [0.001] Found [0] points > Gap Limit (calc errors) [1] Largest Gap Valid [0.00992005] found at Idx [1202] </pre>
Additional Options	<p>General</p>	<p>Not ALL options for to the CATIA V5 Creo View Adapter are made available to the recipe editor.</p> <p>These options are not in common use, but are included here should they ever be required. If additional options are required, then these can be added to the Additional Options field, delimiting each option with a space " " character.</p> <p>This field is functionally equivalent to the additional options file field, however settings made here will override the settings in the options file. This field allows for quick transient tests to be performed, without the need to edit the additional options file. (<i>see below</i>)</p> <p>Some example of additional options are as follows:</p>
	<p>facet_tol <value></p>	<p>Used in conjunction with Surface Checking to adjust the number of facets created (<i>min. value = 0.0001</i>)</p>
	<p>surf_check_max_gap_limit <value></p>	<p>Used in conjunction with Surface Checking to adjust the 'max gap limit' value, which allows reported errors to be discarded if they are greater than a set value.</p>

progress_file <i><file name></i>	<p>The progress file contains a complete audit trail of the translation identifying each element as it is translated from CATIA V5 into the Creo View format. The file will also contain any error messages that may have been generated during the translation. The default location is:</p> <p style="text-align: center;">%TEMP%\tscprogressyj</p> <p>This option allows a different output location to be specified</p>
disable_opacity	<p>Disable the writing of opacity settings into Creo View data</p>
pmi_RGB <i><rrr-ggg-bbb></i>	<p>Set a default colour for PMI text and graphics, this will override the colours read from CATIA V5. The argument rrr-ggg-bbb, MUST be given as 3 values 000 to 255 for each of the colours with a '-' char between, for example:</p> <p style="text-align: center;">pmi_RGB 000-000-000 – for black text pmi_RGB 255-255-255 – for white text</p>
face_opacity	<p>By default individual faces value of opacity is not read. This option enables each face to have its own opacity setting.</p>
opacity_zero <i><value></i>	<p>Allows the user to set a minimum value of opacity. Values are allowed in the range of 0.0 to 1.0 (default 0.1). Values below 0.1 will appear invisible in Creo View</p>
reservations	<p>Enables the conversion of Space Reservations in a faceted form.</p>
reservations_brep	<p>Enables the conversion of Space Reservations in a converted BREP form.</p>
dont_create_udf_axis	<p>Allow Axis Systems to be read as open solids. <i>Note!</i> Axis System read in this way may obscure the Creo View model data – see also udf_axis option.</p>
udf_axis	<p>Ensures Axis Systems are created as axis systems. This ensures that the model in Creo View isn't obscured by very large planes that make up the axis system.</p>
set_omit_large_planes <i><value></i>	<p>Omit large PLANEs greater than the tolerance value (<i>default is 100 M</i>)</p> <p>e.g. set_omit_large_planes 2000 - sets a value of 2km</p>
set_create_datum_planes <i><value></i>	<p>Omitted large PLANEs can be replaced by datum PLANEs (default 35mm). The size of that datum PLANE is controlled with this option.</p> <p>e.g. set_create_datum_planes 150 - sets a value of 150mm</p>
v5_face_fixup	<p>Geometry fixup for faces only. It is rare that this option would be used.</p>

v5_fixup	Geometry fixup for solids and faces. It is rare that this option would be used.
convert_curve_tol <tol>	Allows the convert_curves recipe option default tolerance of 0.00001 to be altered
convert_surface_degree <degree>	Allows the degree for converted NURBS surfaces to be set.
convert_surface_tol <tol>	Allows the convert_surfaces recipe option default tolerance of 0.00001 to be altered
omit_bad_faces	The Adapter can detect a condition where 2D curves have been created, but are outside of the required tolerance, by default these faces will be processed using Creo View's own 2D curves - This option allows this to be disabled, and the face then will be omitted from the solid.
disable_view_zoom	By default the Adapter will zoom to display the viewable PMI/Geometry in a view, this can be disabled using this option
single_jt_file_in_pvoa	If this option is selected ONLY the top level JT file is added to a .pvoa file when a job file (.paj) is processed, otherwise all subordinate part JT files are stored in the .pvoa file - so that a whole assembly is stored in the .pvoa file.
report_non_critical_errors	Enables reporting of errors that are deemed not to be critical to receiving a valid output – e.g. omitting faces
dont_convert_spheres	Note! This option cannot be used in combination with convert_curves or convert_surfaces . When the user wishes to take measurements of the Creo View data, it is preferable to retain any analytical data. This option retains spherical surfaces in their analytic form.
dont_convert_torus	Note! This option cannot be used in combination with convert_curves or convert_surfaces . When the user wishes to take measurements of the Creo View data, it is preferable to retain any analytical data. This option retains torus surfaces in their analytic form.
dont_convert_fillet	Note! This option cannot be used in combination with convert_curves or convert_surfaces . When the user wishes to take measurements of the Creo View data, it is preferable to retain any analytical data. This option retains fillet surfaces in their analytic form.

attr_filter_file <i><filter file></i>	<p>A default Attribute Filter file is supplied in:</p> <p style="text-align: center;"><i>%TS_INST%/data/creoView/defaultAttrFilter.txt</i></p> <p>The default locations can be overridden by specifying a value to the attr_filter_file command. Filtering can be disabled by specifying a non-existing file with 'attr_filter_file' OR deleting the defaultAttrFilter.txt</p> <p>The essential settings for an attr_filter_file are:</p> <p style="text-align: center;"><i>Attribute Name; New Attribute Name; Mode</i></p> <p>Where: Mode = 0 – omit named attribute from Mode = 1 – Rename to New Name</p>
model_based_definitions_2	<p>Setting this option allows the user to remove path data from Specification Tree (Model Based Definition) related attributes. By default attributes read are unchanged. This should ONLY be used in conjunction <i>with Process Specification Tree Enabled or Enabled - Expanded.</i></p>
disable_zoomable_pmi	<p>For flat to screen PMI. If set, PMI Items identified as 'zoomable' will behave such that they do not overlap when zoomed to in the Creo Viewer (A viewer version of > 3.1 needed) In addition relationships between PMI entities will also be maintained, such that the move together. This option is provided to disable this behaviour if it is not required.</p>
zoomable_pmi_std	<p>This option reverses the child-parent in associated PMI entities and is provided as a temporary option while the behaviour is being delivered in advanced of a Creo View viewer that supports this behaviour.</p>
set TS_CREOVIEW_MODEL_BBOX_VALUE=1000	<p>It is now possible (from 23.1 to use an environment variable to set the absolute value of the bounding box so that all data is tessellated to the same accuracy e.g. the value of 1000 would force a bounding box of 1 m³ for tessellation calculations</p>

Additional Options For Composites

read_composites	Read composites data from the CATIA specification tree.
read_parameters	Read additional parameters from the CATIA specification tree.
output_mbd_leaf_nodes	Read sub-part level geometry
enable_view_zoom	Views are zoomed to the part geometry
create_rosette_graphics	Creates the ply-direction rosette
model_based_definitions_1	Read additional mbd data for composites
exclude_list	Excludes a list of named nodes from the output tree
COMPOSITE_PLY_LINEWIDTH=n	Thickens the composite ply boundaries by a factor (n is between 1 and 5)

Additional Options file

Additional Options File	Any of the Additional Options can be specified in an Additional Options File, known as a ' <i>Theorem Configuration File</i> '. Use this option to specify a configuration file to use. See Appendix B for the format of a ' <i>Theorem Configuration File</i> '.
--------------------------------	---

V5 Drawings – Options Related to CATDrawing Processing

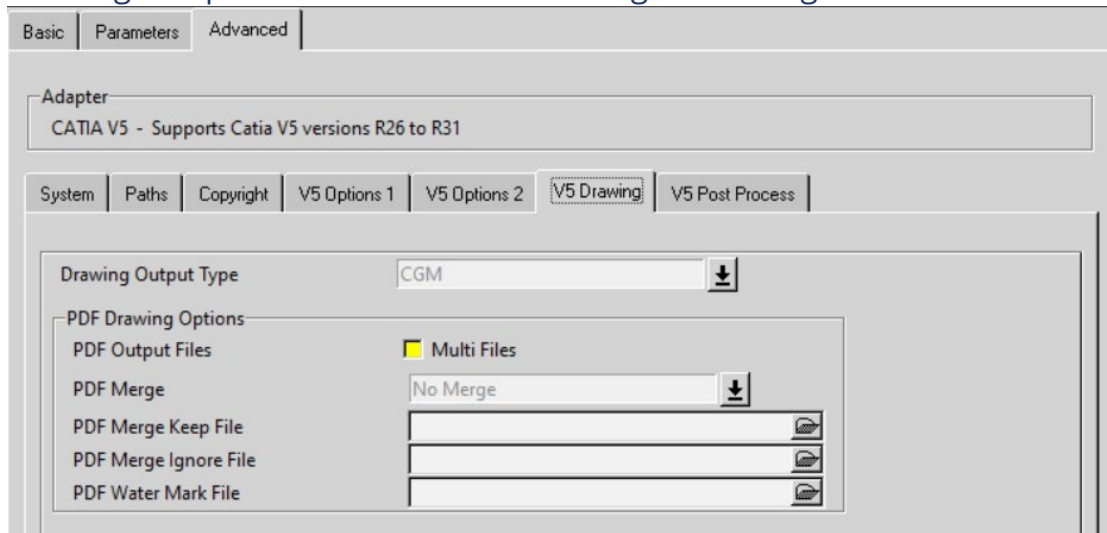

Each of these options is described below:

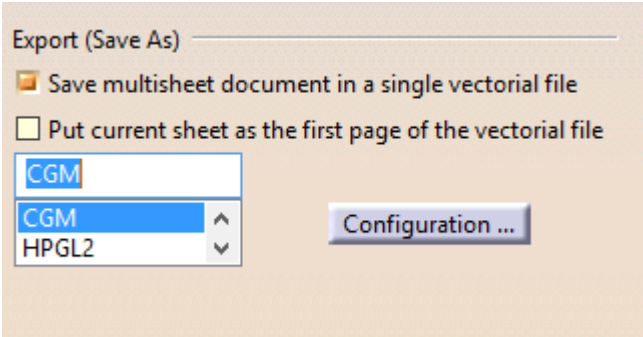
Option	Description
Drawings Output Type	<p>Allows the output format for Drawing processing to be specified. The default is DXF.</p> <p>CGM, PDF, HPGL or TIF can be specified, these options, however, do not offer the multi-sheet output that is present in the DXF format.</p>
Drawing Output Files – Multi-Files	<p>When processing drawing files with multiple sheets, the output is controlled by a combination of the CATIA5 option <i>'save multi-sheet document in a single vectorial file'</i> (v5-save-single-file) and the Multi-Files recipe setting. The CATIA5 v5-save-single-file option can be set in the <i>Tools->Options->Compatibility->Graphics Formats</i> tab:</p>  <p>And controls whether files are written as one per sheet or all sheets in one file.</p> <p>See Appendix C – Drawing Processing Options for how these values should be used</p>
PDF Merge	<p>Note! This option is only available when Drawing Output Type is set to PDF, it is used to add additional control over the election of multiple sheets</p> <p>Note! The Multi-Files option cannot be selected for this option to operate</p> <p>The following options are available from the pull-down:</p>

	<p>No Merge - Default do nothing, this MUST be selected when Drawing type is NOT PDF or PDF Merge is NOT required.</p> <p>PDF Merge</p> <ul style="list-style-type: none"> If the drawing has multiple sheets and multiple PDF files are saved, this option will merge them back to a single PDF document. <p>PDF Merge Ignore Details</p> <ul style="list-style-type: none"> If the drawing has multiple sheets and multiple PDF files are saved, this option will automatically ignore any CATIA V5 drawing sheets in the CATDrawing, that are "Detail" sheets, from being included in the resultant merged PDF output. <p>PDF Merge Keep Files</p> <ul style="list-style-type: none"> If the drawing has multiple sheets and multiple PDF files are saved this option will allow selected sheets to be merged - using the file specified in the PDF Merge Keep File field (See below). The keep file is a simple text file with the drawing sheet names listed one per line, for example : <pre style="margin-left: 40px;">sheet.1 sheet.2 sheet.4</pre> This example will keep sheet's 1,2 and 4 only, in the resultant merged PDF output. <p>PDF Merge Ignore Files</p> <ul style="list-style-type: none"> If the drawing has multiple sheets and multiple PDF files are saved this option will allow selected sheets to be ignored - using the file specified in the PDF Merge Ignore File field (See below). The ignore file is a simple text file with the drawing sheet names listed one per line, for example : <pre style="margin-left: 40px;">sheet.3 sheet.4</pre> This example will ignore (omit) sheet's 3 and 4, the resultant merged PDF output will contain all sheets except sheets 3 and 4.
PDF Merge Keep File	Specify the 'keep' file list for the PDF Merge -> Keep Files setting
PDF Merge Ignore File	Specify the 'ignore' file for the PDF Merge -> Ignore Files setting
PDF Water Mark File	Allows the selection of an image file, in either JPG or PNG format, that will be merged into the PDF file as a watermark. This option only works if one of the the PDF Merge options are selected (i.e. it will NOT work if No Merge is selected). <p>Note! The watermark files are not scaled, the user must provide the correct page size/format to match the input drawing.</p>

V5 SaveAs – Options relating to the Additional formats

Please note! This Processing feature will require additional Theorem licenses.

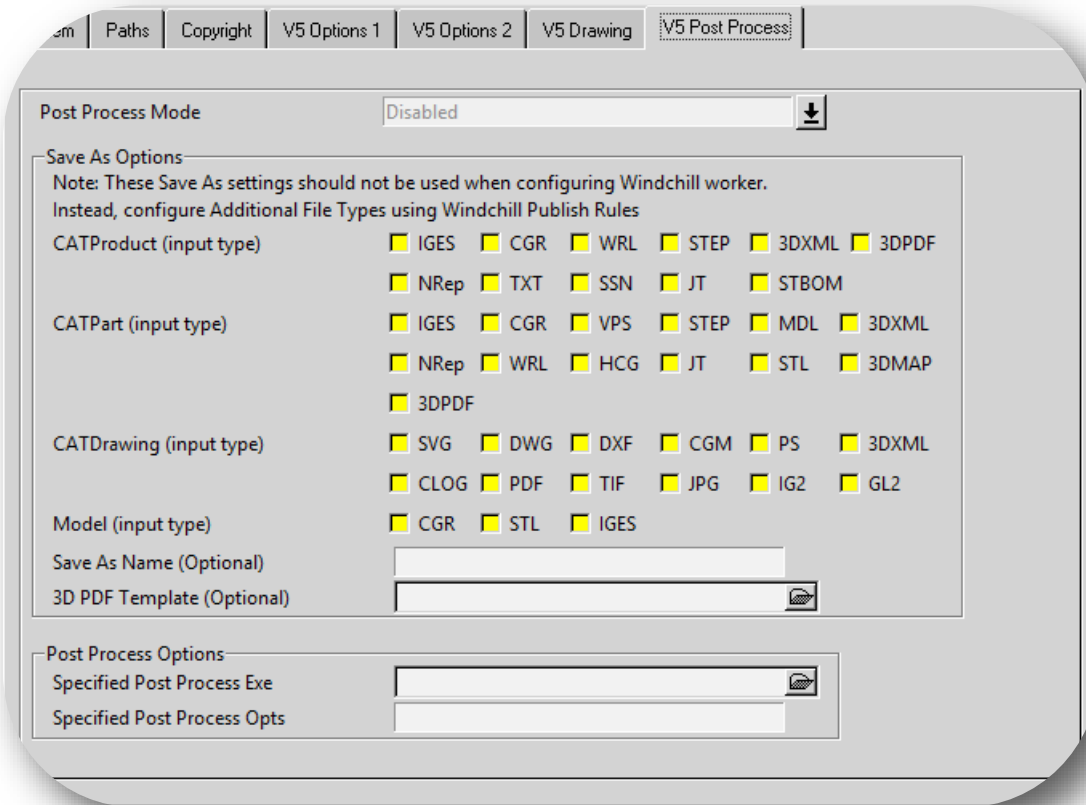

Each of these options is described below:

Please Note! JT export is provided via the CATIA V5 Creo View Adapter – JT Add On module and requires an additional Theorem license. JT export also requires a configuration file to control the output. The default configuration file is located at **%TS_INST%/etc/tessCATIA5.config**. The user can edit this, to suit their tessellation quality and output requirements.

Please Note! 3D PDF export is provided via the CATIA V5 Creo View Adapter – 3D PDF Add On module and requires an additional Theorem license. 3D PDF export also allows for templates to be selected to control the page layout and export options.

Option	Description
Post Process Mode	<p>There are 3 modes available for Post Processing:</p> <p>Disabled</p> <ul style="list-style-type: none"> • Post Process is disabled <p>Saves As</p> <ul style="list-style-type: none"> • Activates the following selections in the page: <ul style="list-style-type: none"> ○ CATproduct SaveAs ○ CATPart SaveAs ○ CATDrawing SaveAs ○ SaveAs Name (optional) <p>Post Process</p> <ul style="list-style-type: none"> ○ Specified Post Process Exe ○ Specified Post Process Opts
Post Processing CATProducts	<p>This set of check boxes allows the selection of the file types to be created when Processing CATProducts AND Post Process Mode is SaveAs</p> <p>Note! SSN denotes a CATIA Session file</p>
Post Processing CATParts	<p>This set of check boxes allows the selection of the file types to be created when Processing CATPart is selected AND Post Process Mode is SaveAs</p> <p>Note! When processing assemblies and using minimum memory mode, any settings in the SaveAs CATPart section will be applied to every part</p> <p>Note! NRep denotes a CATIA NavRep file</p>
Post Processing CATDrawings	<p>This set of check boxes allows the selection of the file types to be created when Processing CATDrawing AND Post Process Mode is SaveAs</p> <p>Note! CLOG denotes a CATIA CATALOG file</p>
SaveAs Name	<p>This field allows the base name of the 'SaveAs' files to be specified, the default being the same name as the input file. When processing assemblies and using minimum memory mode, this name will ONLY apply to the top level assembly – this is to avoid the same name being used for all parts and the assembly</p>
Specified Post Process Exe	<p>When Post Process Mode is set to Post Process, this field allows ANY post process executable or script to be specified – This allows customers to link in their own post processing behaviour.</p> <p>The specified Post Process executable will be called as follows:</p> <p style="text-align: center;"><post_process_exe> <input_file name> <output_folder> <specified arguments> v5_version <CATIA V5 version></p>
Specified Post Process Opts	<p>Specify arguments to be passed to the Specified Post Process Executable</p>

Alternative File Output (*Additional File Types*)

The Adapter supports the generation of the same alternative file types (*Additional File Types*) as listed in the Post Processing SaveAs section, using a WVS Publish Rules 'job' file.

The syntax of invoking the Adapter with a job file is as follows :

```
catia5batch.cmd -j <job_file.paj>
```

Where an example job file format is:

```
<?xml version="1.0" encoding="UTF-8"?>
<publish>
  <input filename="as1.CATProduct"/>
  <output typename="ALTFILE">
    <file display-name="drw1" type="CGR" output-prefix="cc" output-suffix="ss">
    </file>
    <file display-name="drw4" type="IGES" output-prefix="m" output-suffix="uu">
    </file>
    <file display-name="drw5" type="STBOM" output-prefix="h" output-suffix="uu">
    </file>
    <file display-name="drw6" type="TXT" output-prefix="t" output-suffix="uu">
    </file>
    <file display-name="as1" type="PDF" output-prefix="t" output-suffix="uu">
    </file>
    <file display-name="as1" type="JT" output-prefix="t" output-suffix="uu">
    </file>
  </output>
</publish>
```

The **<file...>** elements used in the .paj file result from the same entries being used in Windchill's WVS Publish Rules XML definition for the **<additional-files...>** elements.

This .paj file shows CGR, IGES, STBOM, TXT, PDF and JT files being created for the 'as1.CATProduct' input file. All of the alternate formats (*Additional File Types*) will be packaged into a .pvoa file.

It is important to check that the correct CATIA V5 licenses are available, since some alternative file types (*Additional File Types*) are licensed, This can be carried out via the 'SaveAs' menu option from the CATIA V5 application. If the required type can be saved interactively then the 'Alternative File Output' mechanism should operate successfully.

Please note! The output prefix and output suffix values are added to the output file names generated by the translation, so in the JT example above the resultant file name would be **t_as1_uu.jt**. If these strings are empty the pre/post fix is an "_" (underscore). So, for the JT example above, if both strings were empty the resultant file name would be **_as1_.jt**.

Further details can be found in article **CS111916 - How to configure Additional File Types to be published for specific CAD Document types in Windchill PDMLink ?**

<https://www.ptc.com/en/support/article/CS111916>

Translating Interactively from CATIA V5

The CATIA V5 to Creo View Adapter allows an active CATIA V5 Part or Assembly to be translated directly into Creo View, directly from the CATIA V5 application.

In order to translate from within CATIA V5, the CATIA V5 application must be started from within a Theorem environment, so that the appropriate CATIA V5 menus are loaded.

CATIA V5 can be started from a shortcut, if requested at installation time. Alternatively, it can be started via the script provided in the CADverter installation at:

<installation_directory>\bin\catia5r[version]_start.cmd

(where [version] should be substituted for the version of CATIA V5 that you have installed – e.g. 30, 31, 32):

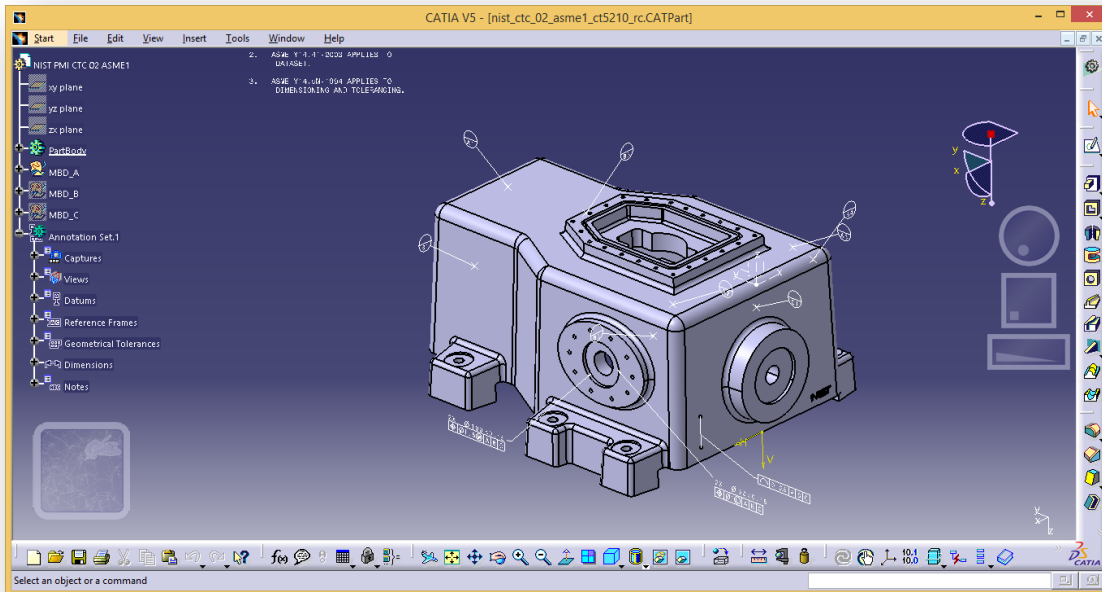

Once CATIA V5 has been started and a model loaded, the active Part or Assembly can be exported to Creo View.

In order to export data to Creo View, the user selects the File -> Export Menu Option:

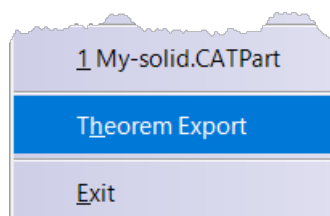

Which in turn launches the Theorem Export panel:

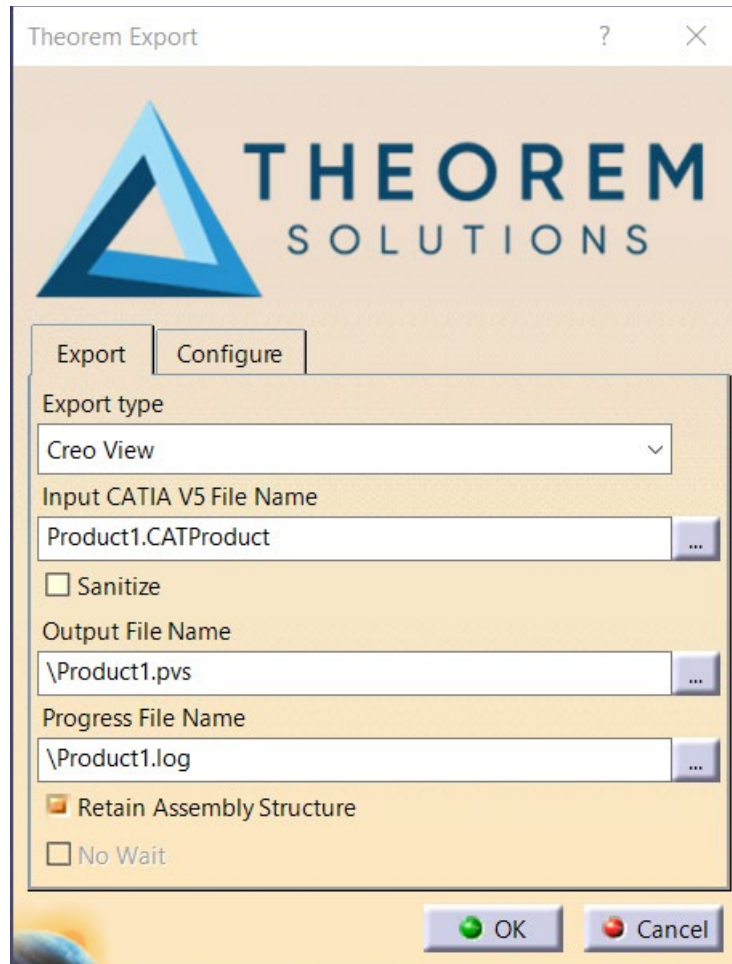

The **Input CATIA V5 File Name**, **Output File Name** and **Progress File Name** fields will be prepopulated if a model is already loaded into the CATIA V5 session. However, these locations can all be modified prior to selecting the **OK** button.

The **Configure** tab allows the user to select a Theorem Configuration:

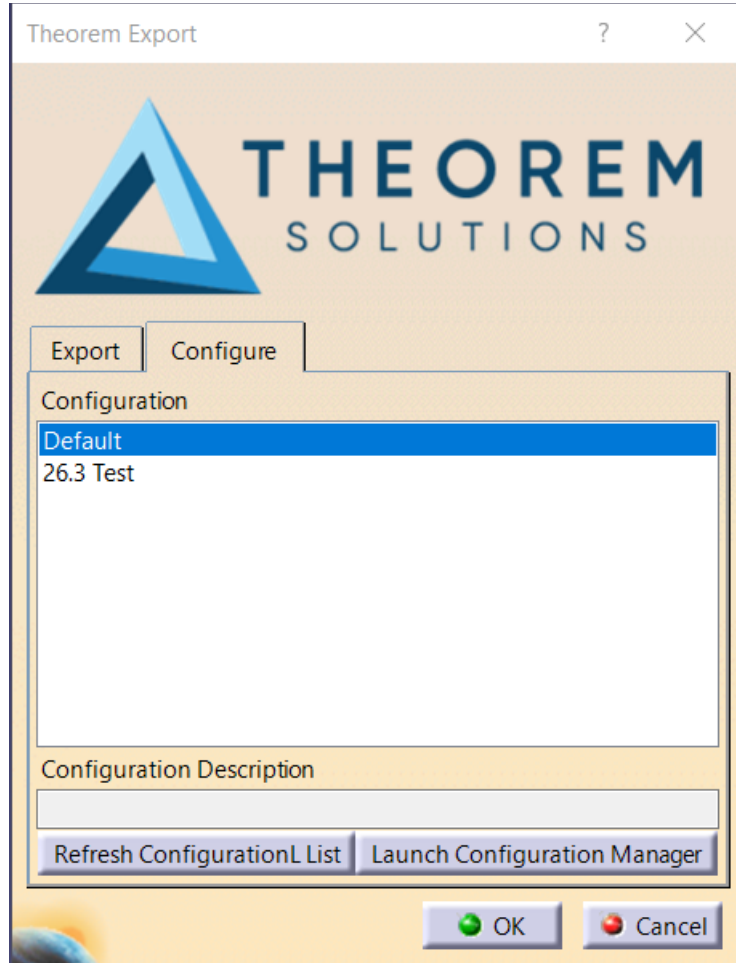

If a suitable Configuration is not available, a new Configuration can be created by selecting the Launch Configuration Manager.

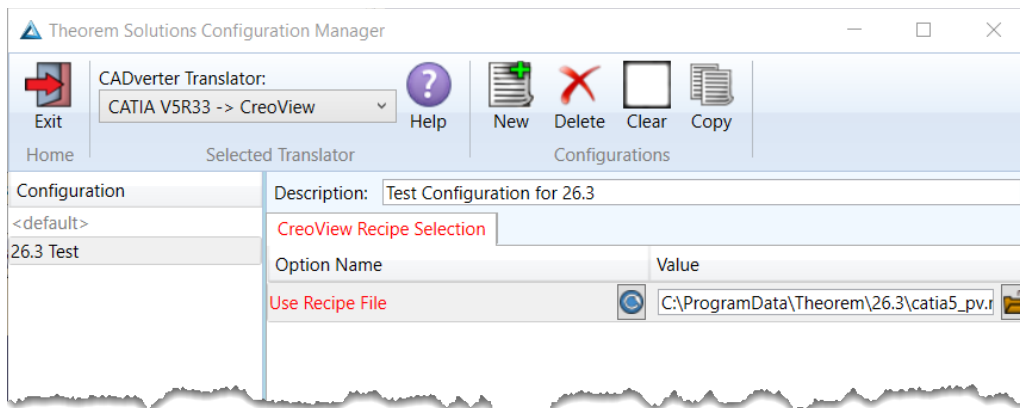

If a new recipe file is required, the recipe editor can be launched using *rcpedit.exe*

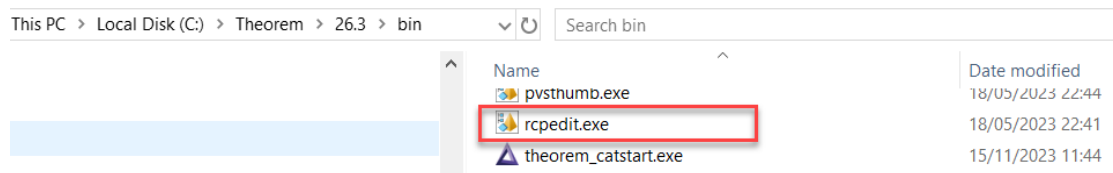

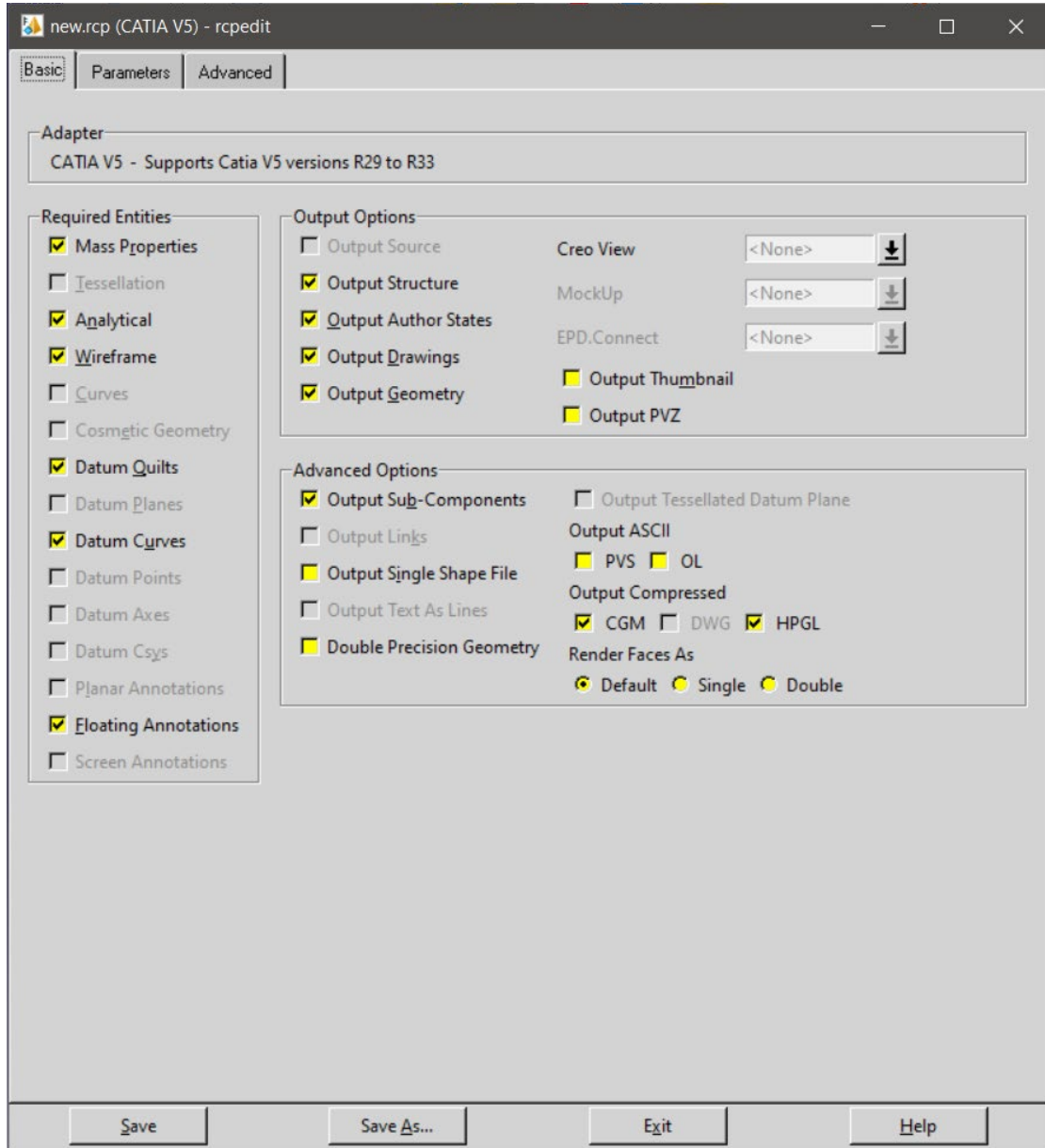

If a user saves or creates a Configuration, then the 'Refresh Configuration List' should be clicked and the configuration selected to make it active.

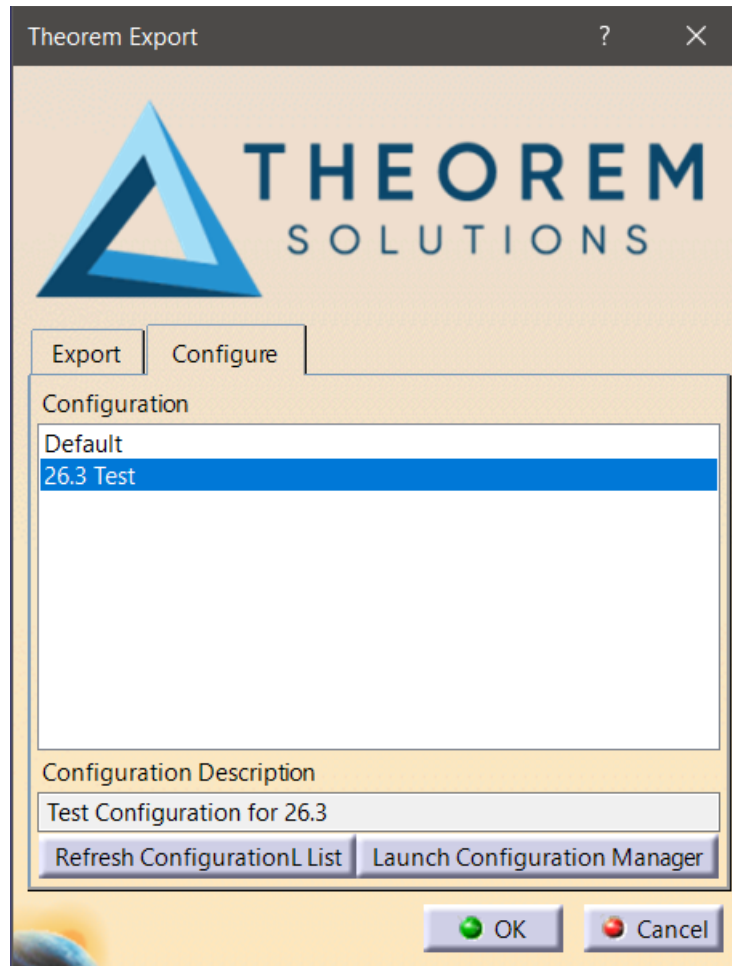

-
- On selecting **OK** the on the Export Panel the active Part or Assembly will be written to Creo View using the into the selected output directory.

Assembly Processing

Processing CATIA V5 Assemblies (.CATProduct files)

Assuming that the input to the Adapter was a single assembly named **test_assembly.CATProduct** related to many subordinate parts (.CATPart) files then the output from the translator will be a single Creo View assembly file **test_assembly.pvs** plus many geometry .ol files, one for each part file processed.

Given that the example assembly file had additional assembly files subordinate to it then all of the accumulated assembly hierarchy information would be output into the top level Creo View .pvs file.

The CATIA V5 Creo View Adapter takes advantage of the latest Creo View dAPI which writes .pvs files (Creo View binary assembly structure files) by default. If a user wishes to write out earlier .pvs versions or .ol files, this can be achieved via the appropriate setting the recipe editor.

Processing CATIA V5 Parts (.CATPart files)

For each part (.CATPart) file processed individually then the output from the translator will be a single Creo View assembly .pvs file and a single geometry .ol file. Therefore assuming that the file being processed was named **test_component.CATPart** then the output would be **test_component.pvs** and **test_component.ol**

Processing CATIA V5 Drawings (.CATDrawing files)

For each drawing (.CATDrawing) file processed individually the translator will output a (by default) DXF (.dxf) file per sheet found in the .CATDrawing file. The final output to the user is a Creo View assembly file and one or many .dxf format files.

Therefore, assuming that the file being processed was named **test.CATDrawing** then the output would be **test.pvs** and **test_sheet1.dxf, test_sheet2.dxf**, etc.

The user can alternatively elect to output drawing files in several formats including CGM, HPGL, PDF or TIF. These can be selected via the recipe editor.

Efficient Large Assembly Processing

If an assembly is opened using the CATIA V5 application or API (CAA), all subordinate assembly and all related geometry will be loaded into memory. This is very inefficient in terms of memory usage.

Using the default Minimum Memory option the Theorem translator has the capability to read assemblies efficiency in the following areas:

- Each .ol file is now written and all associated memory freed on a file by file basis, such that in writing to Creo View there is no build up of memory.
- Although the translation process is constrained by the CATIA V5 API reading all assembly and geometry information into memory, it is now possible to write out each geometry and assembly file on a file by file basis.

The combination of the 2 efficiency improvements detailed here provides in excess of a 20% memory saving on larger (>50MB) assemblies. In general the larger the input assembly the greater the saving will be.

Large Assembly Processing Best Practices

Processing large CATIA V5 assemblies often requires access to large amounts of resources. This can be a combination of both available disk space as well as memory resources. As described above, the default method that the CATIA V5 API uses to consume assembly data compounds this issue. Therefore the following steps are advised as best practices for working with large assemblies:

1. Use the Minimum Memory Mode recipe setting described in section "Running In Minimum Memory Mode".

-
- 2. Enable CATIA V5 Cache Mode and ensure that the assembly has been accessed at least once to generate the cached CGR files.

Cache Mode can be set via the CATIA V5 Tool -> Options -> Infrastructure -> Products Structure -> Cache Management tab, as displayed below:

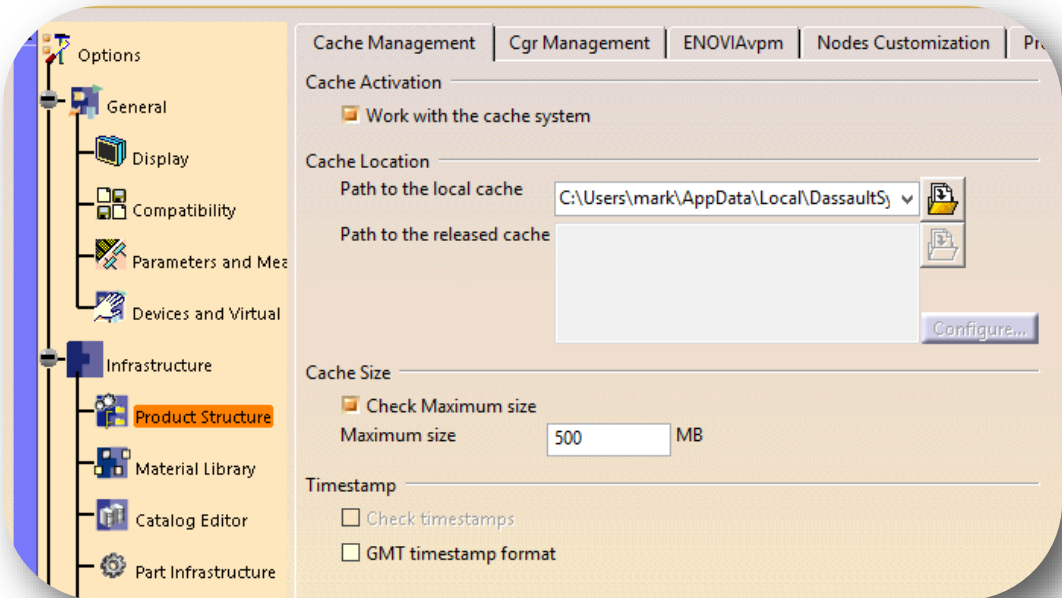

-
- For further assistance with this setting, please refer to your CATIA V5 on-line help.

Error Tracking and Management

A method of tracking and managing errors output from the CATIA V5 to Creo View process has been provided. This is implemented by setting exit status codes from the Adapter and additionally the creation of a summary file for each translation task. The structure of the summary file enables detailed analysis of the translation task to be verified.

Adapter Exit Status Codes

The software will return one of the following exit status codes:

- 0 = Translation completion without errors
- 1 = Translation completed with errors

These codes will be returned regardless of the type of data being processed, either single parts or assemblies. If the error code returned is 1 (e.g. Completed with errors) the user will be directed to look at a summary file that details the exact reason for failure.

Summary File Definition

Each translation creates a summary file using the standard name "tscsummaryj" located in the temporary directory. The user can override the default name using the environment variable TSC_SUMMARY_FILE.

The name of the active summary file is recorded in the progress file:

WINDOWS default name=%TEMP%\tscsummary

Output is recorded in the summary file with a single line reporting a status for each item processed. Each line is defined using 4 fields, separated by a "," character. Each field represents the following data:

- Field 1 = Input File Name
- Field 2 = Error Code ([See Summary File Error Codes](#))
- Field 3 = Error Description ([See Summary File Error Codes](#))
- Field 4 = Progress File name

e.g. C:\myparts\sample.CATPart,0,Completed with no errors,usr\data/sample.CATPart.log

When processing either single parts or assemblies using the default recipe file settings, only one line will appear in the summary file. However for assemblies processed using the minimum memory mode methodology or with links enabled the summary file will contain a line for each ".CATPart" and ".CATProduct" file translated.

Summary File Error Codes

The following Error Codes are output the Summary File:

- 0 = Completed with no errors
- 1 = Command line syntax error
- 2 = Licensing Error
- 3 = Input File Not Found
- 4 = Failed to Open Progress File
- 5 = CATIA V5 Library incompatibility
- 6 = General Read Error
- 7 = General Write Error
- 8 = No entities Found
- 9 = CATIA V5 Environment problem
- 10 = Failed to open CATIA V5 file
- 11 = CATIA V5 Session failure
- 12 = Solid validation error

- 13 = Some solid degradation
- 14 = One or more faces omitted
- 15 = One or more geometry files not found in an assembly
- 16 = Invalid Output Type Specified for Drawing

Worker Logs

The Adapter writes key messages to the PTC worker logs, these include the summary error codes (positive values are used in these logs, e.g. 3 = input file not found).

The Theorem messages added to the worker logs are always prefixed by **'TS:'**, for clarity, and are written at two levels of detail 0x01 and 0x10. These messages are enabled via the **-vm** command line with the correct bit mask level for logs required.

e.g. **-vm 1 will enable all 0x01 messages**
-vm 11 will enable all 0x01 AND 0x10 messages.

The **-vL <log file>** command line can be used to re-direct these messages to a file. In the event of an error the summary code will be written to the worker log the positive value of the summary code :

e.g. **8 => No entities found.**

Process Timeouts

Timeouts allow a user to control when an individual translation invoked from a Windchill environment should timeout.

The Windchill interface allows 2 distinct timeout types to be defined, Long and Short.

Three simple timeouts have been allocated to the CATIA V5->Creo View translator, one using the Short Timeout value and two using the Long Timeout value setting:

- Short Timeout – **Catia5_Access**, providing initial access to CATIA V5
- Long Timeout – **Catia5_Read**, to read each file from CATIA V5.
- Long Timeout – **CreoView_Write**, to write each file into Creo View

The **Timeout values** can be set as follows:

1. Launch the recipe editor: **rcpedit.exe <recipe file name>**
2. Select the Adapter Tab
3. Having selected CATIA V5 from the adapter pull-down, followed by the System Tab, the recipe editor GUI will be displayed as follows:

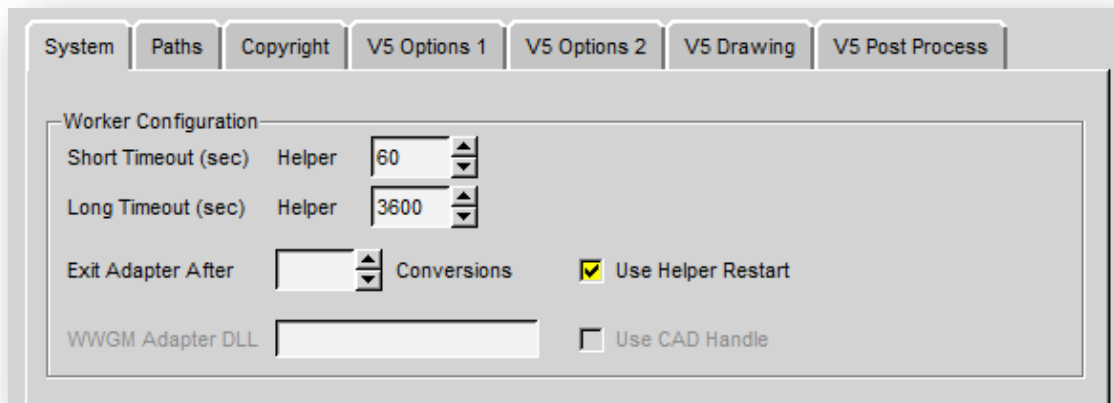

Apply an appropriate time for the Short and Long timeout (in seconds).

Note! These times are totally dependent upon the user data. Some trial and error may be required to define the best times for a specific user environment.

It is recommended that the out-of-the-box default Long and Short Timeouts should NOT be used when running the software with its default settings. They should only be modified when running translations in minimum memory mode or with links enabled. This will allow the LONG timeout setting to be reduced, as using these options will instruct the translator to process assemblies' one part at a time.

Worker Logs

To aid tracking of problematic crashes an environment variable has been added:

```
set TS_V5_CV_DEBUG_DUMP_GCO_DATA=1
```

will create a C:\TEMP\TS_DUMP_V5_PV.vwr (ascii) just prior to the write code commencing. This should only be used under support supervision and recommendation.

Appendix A – CATIA V5 Configuration

Introduction

This Appendix details how to define and configure the CATIA V5 and Theorem environment to work together.

Conventions

Release of CATIA V5

To indicate a release of CATIA V5 the notation <XX> shall be used. This needs to be replaced with the specific release to be used i.e. 29, 30, 31, 32 or 33.

Platform specific directory

Within the installation directory of CATIA V5 there is a platform specific directory i.e. win_b64. This directory shall be referred to as <OSDS> in this Appendix.

Theorem Installation directory

The Theorem translator installation directory is set at installation time in the translator **ts_env.bat** file. This directory shall be noted as <%TS_INST%> in this Appendix.

CATIA V5 Installation Directory

Upon installation of a CATIA V5 product the user will be asked to specify the installation directory. This is the directory which contains the platform specific <OSDS> directory.

Having selected the CATIA V5 installation directory via the browse button, the installation process will record the location of the CATIA V5 installation directory in the ts_env.bat file. This file is located in the Theorem translator installation directory. If the location of CATIA V5 subsequently changes, the translator can be guided to the changed location by modifying this file using a text editor to modify the **ts_env.bat** that is located in the translator installation directory.

If no entry is included for DSLICENSING a warning dialog will be displayed which warns of the empty field. Selecting **Yes** to continue will allow the installation to continue.

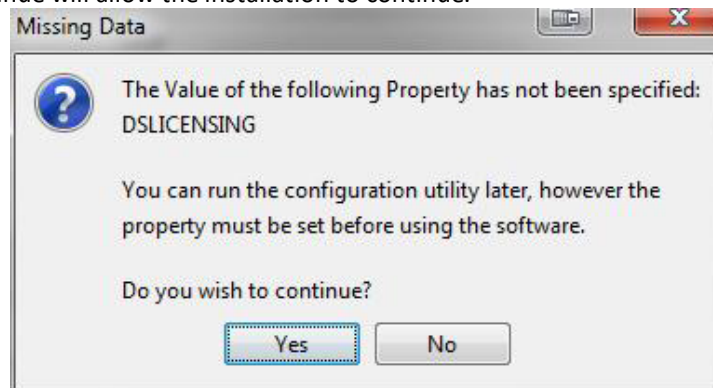

Running CATIA V5 Translators

Before running the translator the user must run CATIA V5 interactively at least once to configure the CATIA V5 environment and license settings. This can be achieved by running the catia5r<XX>_start script as follows:

```
%TS_INST%\bin\catia5r<XX>_start.cmd
```

Once CATIA has been run the Translator can run as described in the relevant product User Guide sections.

CATIA V5 Environment DIRENV & ENV

The default location for CATIA V5 to store its global environment files is in the global Windows 10 & 11:

```
C:\ProgramData\DassaultSystemes\CATEnv
```

Or

```
%APPDATA%\CATEnv
```

You can find this location by running:

```
%CATIAV5_INST%\<OSDS>\code\bin\setcatenv -h
```

The environment files are named in the form **CATIA.V5RN.B<XX>.txt**

If when installing CATIA V5 the default environment file location was replaced with another location then this location needs to be indicated to the CADverter by defining in the **ts_env.bat** the environment variable CATIAV5_DIRENV:

```
set CATIAV5_DIRENV=/some/directory
```

If the Theorem installation is needed to support multiple releases of CATIA. Then the user can define release specific locations using:

```
set CATIAV5R<XX>_DIRENV=/some/directory
```

The Theorem translator will attempt to create its own environment file called **TheoremCatia5R<XX>.txt**. The user must therefore have write permission to the CATEnv directory. If this is not possible an existing environment file can be specified using the variable **CATIAV5_ENV**. e.g.

```
set CATIAV5_ENV=CATIA.V5R32.B32
```

Note. the extension **.txt** is not required. The user can specify a release specific name using **CATIAV5R<XX>_ENV** e.g.

```
set CATIAV5R19_ENV=CATIA.V5R32.B32
```

Checking the CATIA V5 Environment

A script is provided to check that the CATIA V5 environment is set up correctly. In a command window run the command script:

```
%TS_INST%\bin\checkcatia5r<XX>env.cmd
```

Checking the Theorem Shared Library

A script is provided to ensure that the CATIA V5 environment is compatible with the Theorem shared library. In a command window run the command script:

```
%TS_INST%\bin\checkcatia5r<XX>cadverter.cmd
```

A successful output is an indication that the location for CATIA V5 has been specified to the Theorem translator correctly and that the correct version of the Theorem CATIA V5 translator products have been installed.

Appendix B – Theorem Configuration File

Introduction

There are a number of optional pieces of information that can be provided to the Adapter prior to execution. These will control the information that is finally written into the output Creo View file by selecting specific data to be read from the input files processed.

These options are controlled by settings defined within the Theorem CATIA V5_Creo View Adapter configuration file. To invoke these controls it is necessary to create the configuration file and also set identify the configuration filename and location.

Configuration File Format

The configuration file is a simple ASCII text file generated with any available text editor. The format of the file is such that **each configuration command** statement is specified on a **separate line**. Blank characters separate any optional arguments related to the configuration command statement.

e.g.

```
progress_file c:\TEMP\v5_pv.log  
pmi_RGB 000-000-000
```

Configuration File Location

The location of the configuration file can be defined in one of 2 ways. The recommended method is to use the recipe editor. See Setting the Additional Options File Name above.

Alternatively, the 'TS_CFILE' environment variable can be set to point to the CATIA V5 Creo View configuration file prior to starting the translation Adapter:

Syntax: *set TS_CFILE=<configuration_filename>*

e.g. *set TS_CFILE=C:\theorem\data\catia5\configuration.txt*

Appendix C – Drawing Processing Options

Introduction

The following table shows the effect of combined CATIA V5 Tool->Options and the CATIA V5 Creo View Adapter recipe settings:

Drawing Type	V5 save single file	PV Multi-File	Comment
DXF	Enable/Disabled	Enabled/Disabled	Multiple .dxf files are always created for this file type, so v5-save-single-file and Creo View Multi-File have no effect - OK
CGM	Enabled	Enabled/Disabled	Single .cgm file with multiple sheets - OK
CGM	Disabled	Enabled/Disabled	Single .cgm file with single sheet - Not OK
TIF	Enabled/Disabled	Disabled/Enabled	Single .tif file with single sheet – Not OK
PDF	Disabled	Disabled	Multi .pdf files created but only first sheet is viewable – Not OK
PDF	Disabled	Enabled	Multi .pdf files with a sheet per file - OK
PDF	Enabled	Disabled	Single .pdf file – correctly displayed with multiple sheets - OK
PDF	Enable	Enabled	Single .pdf file displayed as individual pages from same file - OK
HPGL	Disabled	Disabled/Enabled	Single .hpgl file created with only first sheet – Not OK
HPGL	Enabled	Enabled/Disabled	Single .hpgl file created with multi sheets - OK
TIF	Enabled/Disabled	Disabled/Enabled	Single .tif file with single sheet – Not OK

Appendix D – Theorem Support Advanced Options

Introduction

The following environment variables are available to modify the Adapters behaviour under the guidance of the Theorem support team.

It is recommended, under guidance from Theorem Support that these variables be set in the **ts_env.bat** file, if required.

Where no value is suggested, set the variable with a value of 1:

e.g.

set TSC_DEBUG_TIME=1

Diagnostics

Variable	Value	Description
TSC_DEBUG_TIME	1	Annotates logs and screen output with time stamps. The Diagnostic Logs -> Info recipe setting must be on
TSC_DEBUG	1 or 2	Annotate logs and screen output with debug data Note! Much of the TSC_DEBUG info is now re-directed via the -vm <level> command line option into the worker log
TSC_EXT_REF	1	Output specific debug for external references
TSC_LEAVE_GCO	1	Retain any intermediate GCO files

Filtering

Variable	Value	Description
TS_NO_ROUGHNESS	1	Disable PMI roughness types
TS_OMIT_ATTRIBUTES	1	List of attribute names to be omitted
TS_DISABLE_OMIT_ATTRIBUTES	1	Allow all attributes through

Options

Variable	Value	Description
TSC_EXT_REF_ASSY	1	Include Assemblies as an external reference set
TSC_DISABLE_LARGE_ASSY_PARTS	1	For large assembly processing, omit geometry processing
TS_DISABLE_PRIMSOL_WR	1	Disable the ability to write GCO PRIMSOL data (CATIA V4 pipes)
TSC_CFILE	1	Import general command line options via a file input

Representations

Variable	Value	Description
REPRESENTATIONS		Causes all representations for a node to be read
REPRESENTATION	<Name>	Causes the named representation for a node to be read. If this does not exist then else the default representation will be read

Positional Assembly Testing

This is a special set of options used to test positional assembly outside of Windchill, and possibly provide some control on its behaviour, these options offer NO benefits for end users.

Variable	Value	Description
TS_TEST_POSITIONAL_ASSY	1	Simulate Positional Assembly mode in Windchill
TS_TEST_WORKER_MODE	1	Simulate Worker Mode in Windchill
TS_POSITIONAL_ASSY_DEPTH	1	Allow the depth of the read of positional assembly to be adjusted
TS_CATPRODUCT_IGNORE_FALLBACK	8-bits	001 – Ignore REFASSYNAME check 010 – Ignore signal event check 100 – Ignore NETS=0 check 111 – All on

JT Configuration File

When saving JT files a default JT configuration file will be used, if the user wishes to specify a different configuration file these is achieved by setting the environment variable:

```
set TS_WCV_JT_SAVEAS_OPTIONS=-z %TS_INST%\etc\tessSomeOther.config
```

Note! The -z <config file> syntax

The additional options field can also be used in the recipe editor to specify a JT configuration file via:

```
-z <full path to JT config file>
```

Alternate File Format (Additional File Types)

When JT is selected as alternative format using the JT Add On module, the JT configuration file allows the output name to be sanitized.

Some characters are invalid in a JT context and need to be changed during the translation process. The Adapter is shipped with a default set of characters to be mapped to the allowable character of “_”. These characters are:

```
\n|r|t`~!@#$$%^&*()-+=|\"'";:./<>?|[]{}
```

It is important, particularly in a Windchill context, that the resultant JT file can be found, as it will need to into an expected .pvoa file.

This string of invalid characters used by the JT Add On can be set by the user, via the environment setting :

```
set TS_V5_CV_JT_INVALID_CHARS="\n\r\t`~!@#$$%^&*()-+=\|'\"';,: /<>?|[]{}"
```

This name sanitation string would have to mirror the Filter- >FilenameSanizationSet value in the JT config file. It is suggested that Theorem support be contacted in the unlikely event that this should be used.

Restart

When the Adapter is used in a Windchill context, in some circumstances the worker process may require a restart. For example, when there are no CATIA V5 licenses available. This behaviour can be enabled by a recipe setting:

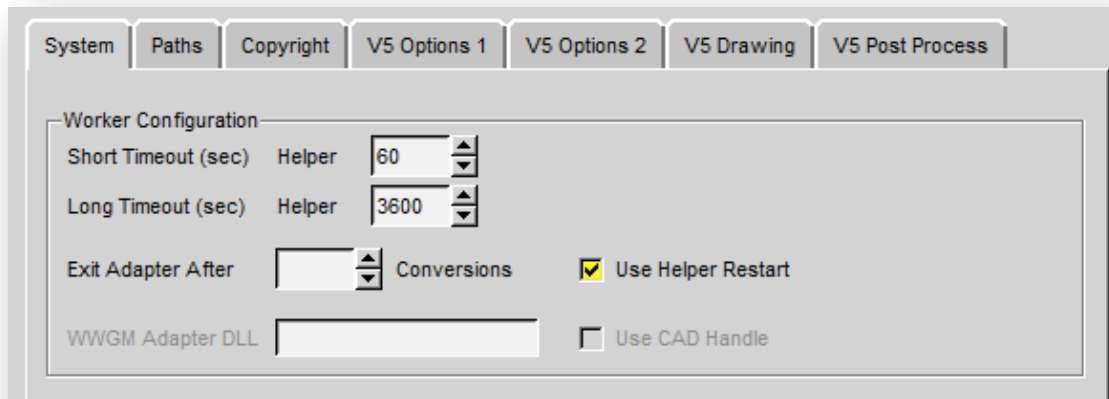

In addition to the recipe setting an environment variable setting is required to ensure that the end-user deliberately wants to switch on the restart functionality.

Variables can also be set to run a user defined script that can carry out specific actions at the time of restart, e.g. stopping other processes and cleaning temporary directories

Variable	Value	Description
TS_CREOVIEW_RESTART_CONFIG	1	Switch on Windchill Restart
TS_V5_CV_RUN_STARTUP_SCRIPT	<name>	The name of a script that is run by the catiastart.bat script when the worker is restarted
TS_V5_CV_TEMP_CACHE_DIR	<dir>	Folder to delete when the worker is restarted

PMI Options

if flat to screen OR flipped PMI is enabled the PMI nodes may be split between the PMI and leader data. In these cases, PMI and Leader nodes are by default associated so that if the PMI text is selected, so is the leader. This can be disabled via - env var :

```
TS_V5_CVW_PMI_PMI_OMIT_LEADERS=1
```

Attribute Filter additions

There have been several additions made to the default attribute filter file

```
PARENT_PMI_ID,,0,,,
ASSOCIATED_GROUP_ID,,0,,,
PART CAPTURE VIEW,,0,,,
INFINITE,,0,,,
LINE_TYPE,,0,,,
LINE_WIDTH,,0,,,
SYMBOL_TYPE,,0,,,
SYMBOL_SUB_TYPE,,0,,,
CGR_EDGE_TYPE,,0,,,
```

Screen Output

By default error messages are reported to a temporary log file:

%TSC_TEMP_DIR%\ts_v5_pv_stderr.log

Error messages can be redirected by setting the variable below:

Variable	Value	Description
TS_OUTPUT_STDERR	1	Redirects error messages to the screen log, or a log specified via the -vL command line argument

Worker Logs

If **-vm <level>** worker logs are enabled and not re-directed to a log file, then these messages will default to stderr and be written to the `ts_v5_pc_stderr.log`

Animation Files

Motion file units can be specified:

Variable	Value	Description
TS_MOTION_FILE_UNIT	m, cm, inch, feet, yard or value	Specify a unit or a value – where value is mm/unit required

PVZ Output

PVZ Output can be enabled by setting the recipe editor setting:

adapter/outputPvz=1

Issues Creating a CATIA V5 Worker

In the unlikely scenario that the recipe editor displays the **create catia5Worker** button greyed out then it is necessary to run the `%TS_INST%\bin\pview.reg` file. This updates the registry and will enable this button.

Managed CGR (aka SuperCGR)

Managed or SuperCGR (PTC terminology) is the capability provided via the Adapter to allow a CGR file to be created for the CATPart or CATProduct at the same time as generating the Creo View output data

This capability is the forerunner to the Post process SaveAs capability, so is only used by few customers. The function is switched on via a hidden recipe file setting:

adapter/output_CGR=my_cgr_file_name

This will result in a file being created in the Creo View output directory named ***my_cgr_file_name.cgr***

Alternatively:

adapter/output_CGR=

will result in a file being created in the Creo View output directory named after the input CATPart/CATProduct file name.

For customer using Managed CGR, this Adapter setting is set by the Windchill worker mechanism.

When processing assemblies the output will always be a single CGR file, regardless of the conversion mode setting (i.e. standard or minimum memory).

An additional option can be used to provide an alternative output directory for the generate CGR files.

A FULL path when using this option:

adapter/output_CGR_Path=C:\\TEMP\\target_cgr_output_path

Note! double back slashes are required for Windows paths.

Tessellation Settings

In the unlikely event that a user should want to alter the tessellation settings in the Creo View output, the following settings can be manually added and modified in the recipe file under guidance from your PTC representative:

adapter/lod=Standard
adapter/chordHeight=0.1

would result in a higher level of tessellation, and so consequently a larger file is produced.

adapter/lod=Standard
adapter/chordHeight=10.0

would result in a lower level of tessellation, and so consequently a smaller file is produced.

Instance Naming

Variable	Value	Description
INSTANCE_NAMING	V5	This advanced argument causes the part names in Creo View to be displayed in accordance with the Tools->Options->Infrastructure->Product Structure->Nodes Customization panel (see Below)
INSTANCE_RENAMING	<STRING>	Allows this to be specified on the command line. Details of the options are shown below

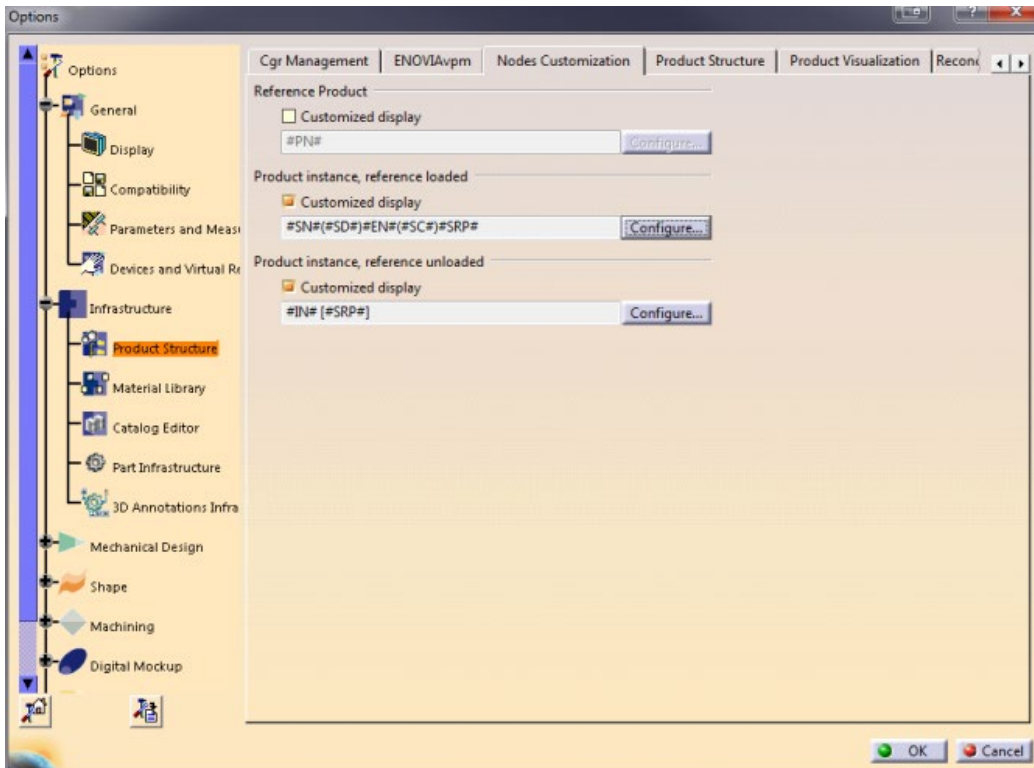

An example naming configuration is shown below

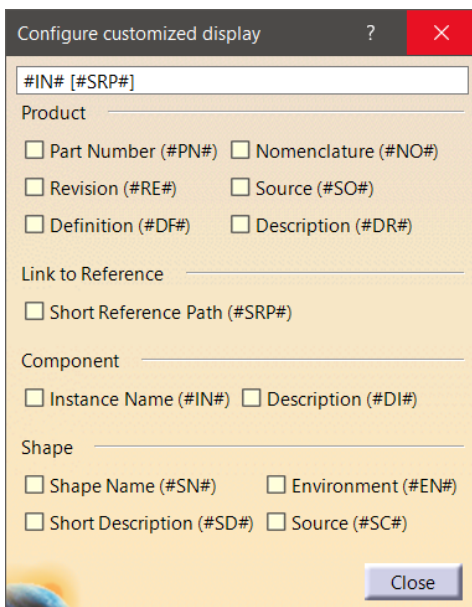

The code looks for the **##XX#** type string finds the appropriate attribute and replaces it in the string
 Note that care should be taken when assigning these names as you can end up with both duplicated names and/or empty names.

Also support for the rename specification on the command line using the option is available where **<string>** can be combination of :-

- Product,
- #PN#** - Part Number,
- #NO#** - Nomenclature,
- #RE#** - Revision,
- #SO#** - Source,
- #DF#** - Definition,

#DR# - "Description",
- Link to Reference,
#SRP# - Short Reference Path,
- Component,
#IN# - Instance Name,
#DI# - Description,
- Shape,
#SN# - Shape Name,
#EN# - Environment,
#SD# - Short Description,
#SC# - Source

Setting it to V5 will replicate the naming style from the CATIA V5 CATSettings

Flat to screen OR flipped PMI

If these are enabled the PMI nodes are split between PMI and leader data, in these cases, PMI and Leader nodes are by default associated so that if the PMI text is selected, so is the leader.

This can be disabled via - env var :

```
TS_V5_CVW_PMI_PMI_OMIT_LEADERS=1
```

Solid Naming for Expand Parts

It is possible to name solids created by expand part to a more understandable when solid names have been used in CATIA. This is turned on by the command:

```
feature_name
```

This is intended to be the default and will change in a future revision.



THEOREM
SOLUTIONS

**UK, Europe and Asia
Pacific Regions**



THEOREM HOUSE
MARSTON PARK
BONEHILL RD
TAMWORTH
B78 3HU
UNITED KINGDOM



sales@theorem.com



+44 (0) 1827 305 350

USA and the America



THEOREM SOLUTIONS INC
100 WEST BIG BEAVER
TROY
MICHIGAN
48084
USA



Sales-usa@theorem.com



+ (513) 576 1100



THEOREM.COM